



Union Special[®]
INDUSTRIAL SEWING EQUIPMENT

STYLES

ILLUSTRATED PARTS LIST

52700BK

52700BL

52700BM

52700BN

52700BP

52700BR

52700BS

52700BT

52700BU

52700BV

**52700 CLASS STREAMLINED FIFTY
THOUSAND SERIES**

**CATALOG NO.
115N**

**SECOND
EDITION**

Catalog No. 115 N

LIST OF PARTS

For Styles

52700 BK
52700 BL
52700 BM
52700 BN
52700 BP

52700 BR
52700 BS
52700 BT
52700 BU
52700 BV

Second Edition

Copyright 1963

By

Union Special Corporation
Rights Reserved in All Countries

UNION SPECIAL CORPORATION

INDUSTRIAL SEWING MACHINES

Printed in U.S.A.

Reprinted 9/92

IDENTIFICATION OF MACHINES

Each UNION SPECIAL machine is identified by a Style number which is stamped into the name plate on the machine. Style numbers are classified as standard and special. Standard Style numbers have one or more letters suffixed, but never contain the letter "Z". Example: "Style 52700 BK". Special Style numbers contain the letter "Z". When only minor changes are made in a standard machine, a "Z" is suffixed to the standard Style number. Example: "Style 52700 BKZ".

The over-all width of the stitch or the distance between the outside needles (extreme left and right) is represented by a gauge number. The actual spacing between the center lines of the outside needles, as applied to these machines, is as follows: No. 8 gauge .125", No. 12 gauge .172" and No. 16 gauge .234".

Styles of machines similar in construction are grouped under a class number which differs from the style number in that it contains no letters. Example: "52700".

APPLICATION OF CATALOG

This catalog applies specifically to the standard Styles of machines as listed herein. It can also be applied with discretion to some Special Styles of machines in this class. Reference to direction, such as right, left, front, back, etc., are given from the operator's position while seated at the machine. Operating direction of handwheel is toward the operator.

STYLES OF MACHINES IN CLASS 52700

High Speed Streamlined Flat Bed Medium Throw Machine, Two and Three Needles Abreast, Double Disc Take-up, One Looper, Needle Bearing Needle Bar Drive, Light Weight Presser Bar and Needle Bar Driving Mechanism, Single Reservoir Enclosed Automatic Lubricating System, Filter Type Oil Return Pump, Oil Pump Base Plate and Oil Siphon Assembly. Lateral Looper Travel, Work Space to Right of Needle Bar 7 3/4 Inches.

52700 BK Two Needle, Plain Feed Machine, for making belt loops for trousers, overalls, bathrobes, and for similar operations on medium to medium heavy weight materials. Strips used in short lengths. Belt loops are 3/32 inch wider than needle spacing of machine. Standard gauges Nos. 12 and 16. Seam specification 406-EFh-1. Type 128 GAS needle.

52700 BL Two Needle, Plain Feed Machine, for hemming sides and bottoms of bathrobes, and for similar operations on medium to medium heavy weight woven fabrics. Standard gauges Nos. 12 and 16. Seam specification 406-EFa-1. Type 126 GS needle.

52700 BM Three Needle, Plain Feed Machine, for attaching elastic bands in long lengths, garment lengths or with ends joined, to rayon, silk, cotton, nylon and wool, flat, warp and ribbed knit garments, and for similar operations on light to medium weight material. Automatic stretching device and spool holder for elastic. Standard gauge No. 16 only. Seam specification 407-LSb-1 inverted. Type 121 GBS needle.

52700 BN Two Needle, Plain Feed Machine, for attaching elastic bands in long lengths, garment lengths, or with ends joined, to rayon, silk, cotton, nylon and wool, flat, warp and ribbed knit garments, and for similar operations on light to medium weight material. Automatic stretching device and spool holder for elastic. Standard gauges Nos. 8, 12 and 16. Seam specification 406-LSb-1 inverted. Type 121 GS needle.

STYLES OF MACHINES IN CLASS 52700 (continued)

- 52700 BP Two Needle, Plain Feed Machine, for attaching elastic in long lengths, 3/8 to 1 1/4 inches wide, to rayon, silk, cotton, nylon and wool, flat, warp and ribbed knit garments, and for similar operations on light to medium weight materials. Equipped with elastic metering device. Seam Specification 406-LSb-1 inverted. Type 121 GS needle.
- 52700 BR Two Needle, Plain Feed Machine with under trimmer, for attaching elastic bands in long lengths, 1/4 to 1 1/2 inches wide, to rayon, silk, cotton, nylon and wool, flat, warp and ribbed knit garments, and for similar operations on light to medium weight material. Standard gauges Nos. 8 and 12. Seam specification 406-LSa-1. Type 121 GBS needle.
- 52700 BS Three Needle, Plain Feed Machine with under trimmer, for attaching elastic bands in long lengths, 3/8 to 1 1/2 inches wide, to rayon, silk, cotton, nylon and wool, flat, warp and ribbed knit garments, and for similar operations on light to medium weight material. Standard gauge No. 16 only. Seam specification 407-LSa-1. Type 121 GBS needle.
- 52700 BT Same as 52700 BR, except fitted with thumbscrew adjusted differential feed. Furnished only in No. 8 gauge. Type 121 GBS needle.
- 52700 BU Same as 52700 BS, except fitted with thumbscrew adjusted differential feed. Type 121 GBS needle.
- 52700 BV Same as 52700 BR, except without under trimmer, but fitted with body folder for turning body of garment upwardly. Furnished only in No. 12 gauge. Seam specification 406-LSb-1. Type 121 GBS needle.

NEEDLES

Each UNION SPECIAL needle has both a type number and a size number. The type number denotes the kind of shank, point, length, groove, finish and other details. The size number, stamped on the needle shank, denotes the largest diameter of blade measured in thousandths of an inch, midway between the shank and the eye. Collectively, the type number and the size number is the complete symbol.

The type numbers of the needles recommended for each style of machine covered by this catalog are given in the machine style description. Other needles are available, but the ones indicated are those recommended to produce the most satisfactory results. The type numbers of the recommended needles, together with their descriptions and the sizes available, are listed below:

<u>Type No.</u>	<u>Description and Sizes</u>
121 GS	Round shank, round point, short, double groove, struck groove, chromium plated - available in sizes 065/025, 070/027, 075/029, 080/032, 090/036, 100/040, 110/044, 125/049, 140/054.
121 GBS	Round shank, round point, short, single groove, struck groove, spotted, ball point, chromium plated - available in sizes 065/025, 070/027, 075/029, 080/032, 090/036, 100/040.
126 GS	Round shank, round point, short, double groove, struck groove, ball eye, chromium plated - available in sizes 080/032, 100/040, 054.
128 GAS	Round shank, round point, short, double groove, struck groove, ball eye, spotted, chromium plated - available in sizes 080/032, 090/036, 100/040, 110/044, 125/049, 140/054, 060, 067.

To have needle orders promptly and accurately filled, a sample needle, the empty package, or the type and size number should be forwarded. Use description on label. A complete order would read as follows: "1000 Needles, Type 121 GBS, Size 070/027".

NEEDLES (continued)

Selection of proper needle size should be determined by the size of the thread used. Thread should pass freely through the needle eye in order to produce a good stitch formation.

ORDERING REPAIR PARTS

ILLUSTRATIONS

This catalog has been arranged to simplify ordering repair parts. Exploded views of various sections of the mechanism are shown so that the parts may be seen in their actual position in the machine. On the page opposite the illustration will be found a listing of the parts with their part numbers, descriptions, and the number of pieces required in the particular view being shown.

Numbers in the first column are reference numbers only, and merely indicate the position of that part in the illustration. Reference numbers should never be used in ordering parts. Always use the part number listed in the second column.

Component parts of sub-assemblies, which can be furnished for repairs, are indicated by indenting their descriptions under the description of the main sub-assembly. Example:

10	29476 LE	Looper Driving Lever Crank Assembly-----	1
11	22587	Screw, upper -----	2
12	22729 D	Screw -----	1
13	51243 C	Ball Stud Guide-----	1
14	22559 A	Screw, lower -----	2

It will be noted in the above example that the eccentric and bearing are not listed. The reason is that replacement of these parts individually is not recommended, so the complete sub-assembly should be ordered.

In those cases where a part is common to all of the machines covered by this catalog, no specific usage will be mentioned in the description. However, when the parts for the various machines are not the same, the specific usage will be mentioned in the description, and if necessary, the difference will be shown in the illustration.

At the back of the book will be found a numerical index of all the parts shown in this book. This will facilitate locating the illustration and description when only the part number is known.

IDENTIFYING PARTS

Where the construction permits, each part is stamped with its part number. On some of the smaller parts, and on those where the construction does not permit, an identification letter is stamped in to distinguish the part from similar ones.

Part numbers represent the same part, regardless of the catalog in which they appear.

IMPORTANT! ON ALL ORDERS, PLEASE INCLUDE PART NAME AND STYLE OF MACHINE FOR WHICH PART IS ORDERED.

TERMS

Prices are net cash and are subject to change without notice. All shipments are forwarded f. o. b. shipping point. Parcel Post shipments are insured unless otherwise directed. A charge is made to cover postage and insurance.

OILING AND THREADING DIAGRAM

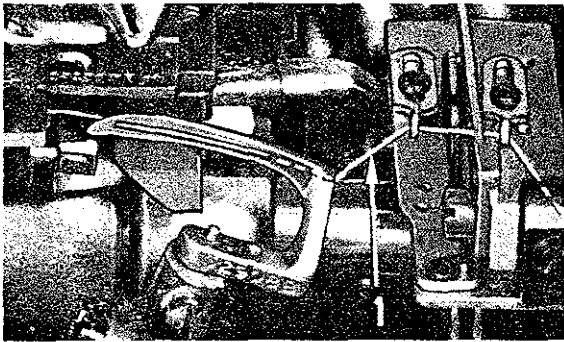
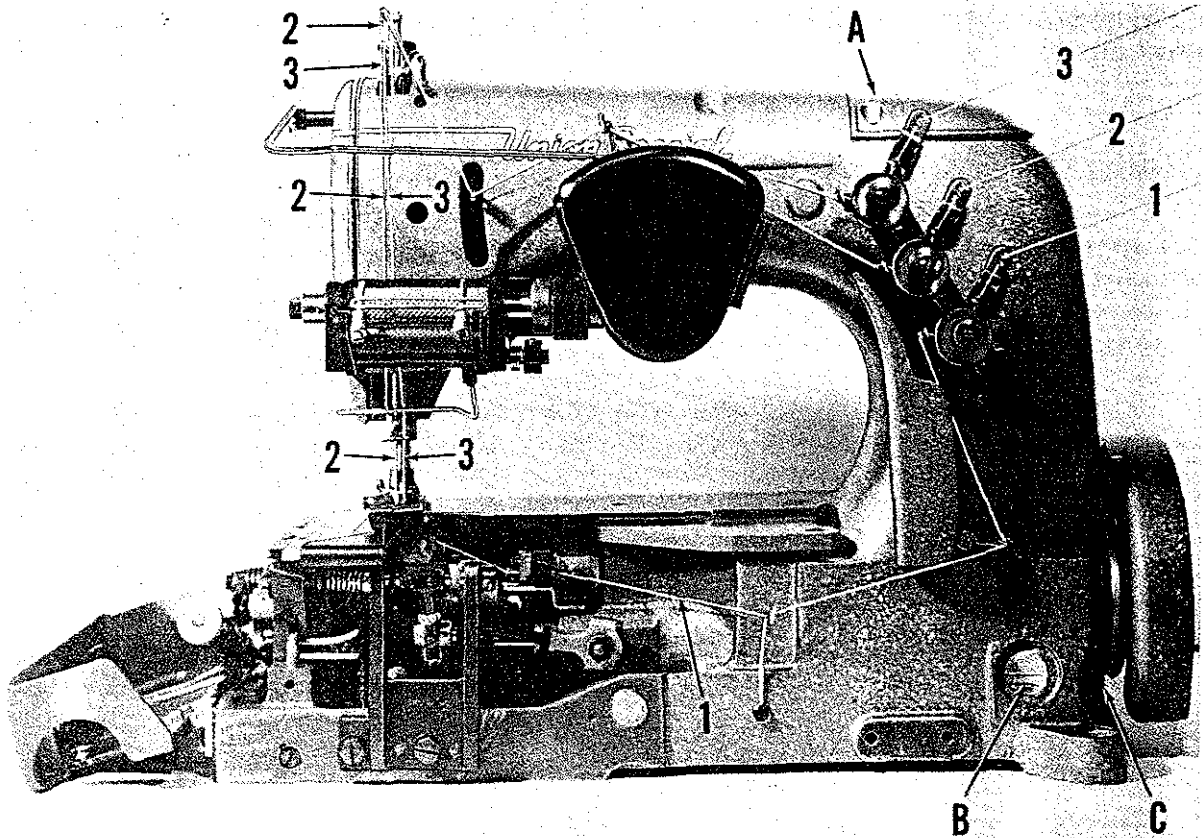

The oil has been drained from the machine before shipping, and the reservoir must be filled before beginning to operate. Use a straight mineral oil with a Saybolt viscosity of 90 to 125 seconds at 100° Fahrenheit.

Oil is filled at the spring cap "A" in the top cover, and the level is checked at the sight gauge "B" on the front of the machine. The oil level should be maintained between the red lines on the gauge. The capacity of the oil reservoir is 12 ounces.

The machine is automatically lubricated, and no oiling, other than keeping the main reservoir filled, is necessary.

A daily check before the morning start should be made, and oil added if required. Oil which has gone through the machine is filtered and pumped back into the main reservoir, making too frequent oilings unnecessary. Excessive oil in the main reservoir may be drained at the plug screw "C" in the main frame directly under the handwheel.

Above are pictures showing the manner in which the 52700 Styles covered in this catalog are threaded. The three needle machines are threaded in substantially the same manner. The looper threading has been enlarged for clarity.

SELF-PRIMING HEAD OIL SIPHON

Class 52700 machines are equipped with a self-priming head oil siphon. When the machine is started, oil splashes on the priming cup felts, filters through the felts, and trickles down the vertical oil tube, thus, priming the siphon. Once the prime is established, it is maintained, unless the felts are removed. The siphon operates twenty-four hours a day, removing oil at the rate of six to twelve drops per minute, which of course, far exceeds the rate at which oil collects in the head.

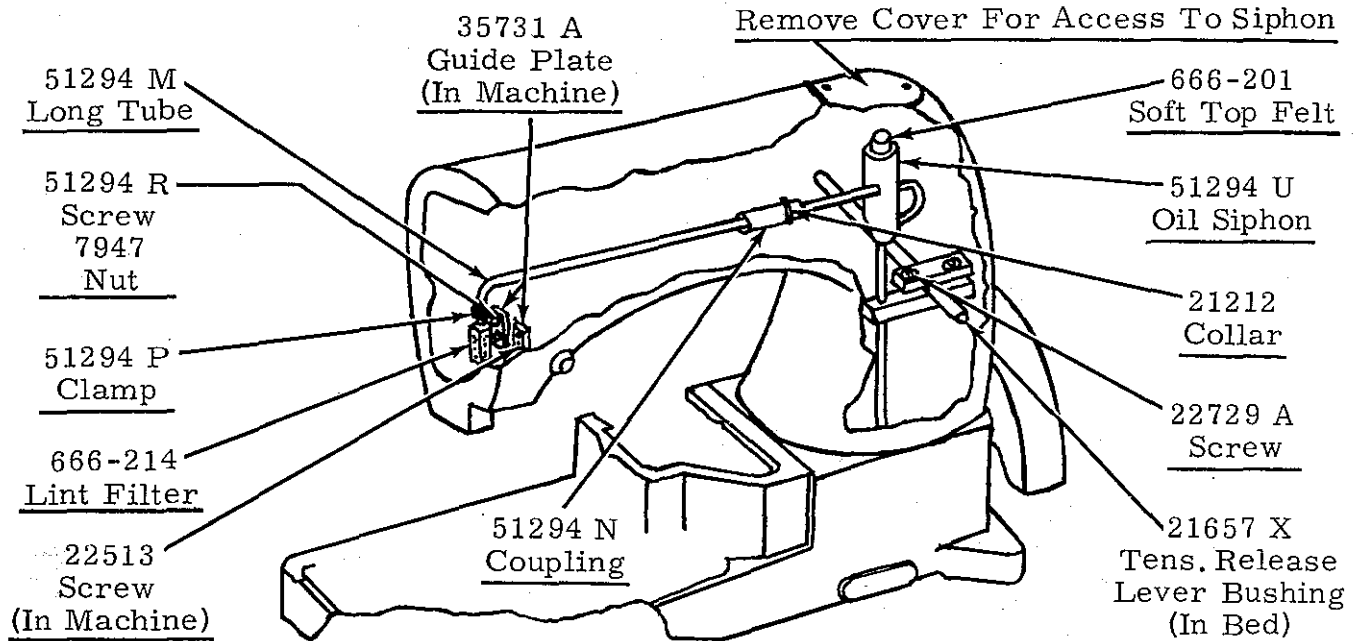

INSTALLING AND MAINTENANCE OF OIL SIPHON

A newly installed siphon starts its action within three to five minutes after the machine is operating. However, it may be twenty minutes or so before all the air is removed from the line and the siphon is in full operation. Within an hour, there is a distinct drop in oil level in the head sump.

The felts in the priming cup are designed for a specific purpose. The bottom felt, 666-209, is thin and relatively dense, to meter the flow of priming oil and to prevent the entrance of air. The softer top felt, 666-201, is a filter to prevent the clogging of the metering felt. This felt, at the intake of the siphon, keeps the siphon clear of lint, and prevents the entrance of air at that point. For the best initial self-priming condition, the felts of the siphon should be dry. In this condition, it is difficult for air to be trapped between the felts or in the top soft felt itself.

However, if for some reason the priming cup felts had been oiled before installing, the siphon may fail because air is trapped between the felts or in the soft top felt. As a precaution, remove the soft felt from the cup. Then, while squeezing the felt between the fingers, saturate it well with oil. In other words, squeeze out the air and replace it with oil. Then, completely fill the cup with oil, and push or twist the soft felt down into cup so that it definitely contacts the harder thin felt. This precaution prevents the trapping of air, and no trouble should be experienced when starting the siphon.

If you want to be doubly sure that the siphon is functioning correctly, on a machine in operation, apply a certain amount of oil in the sump around the felt in the head. Before doing this, be certain that this felt has been saturated in the same manner as explained for the soft felt in the top of the siphon cup. When this is done, the siphoning action will begin, and the oil will be removed as explained.

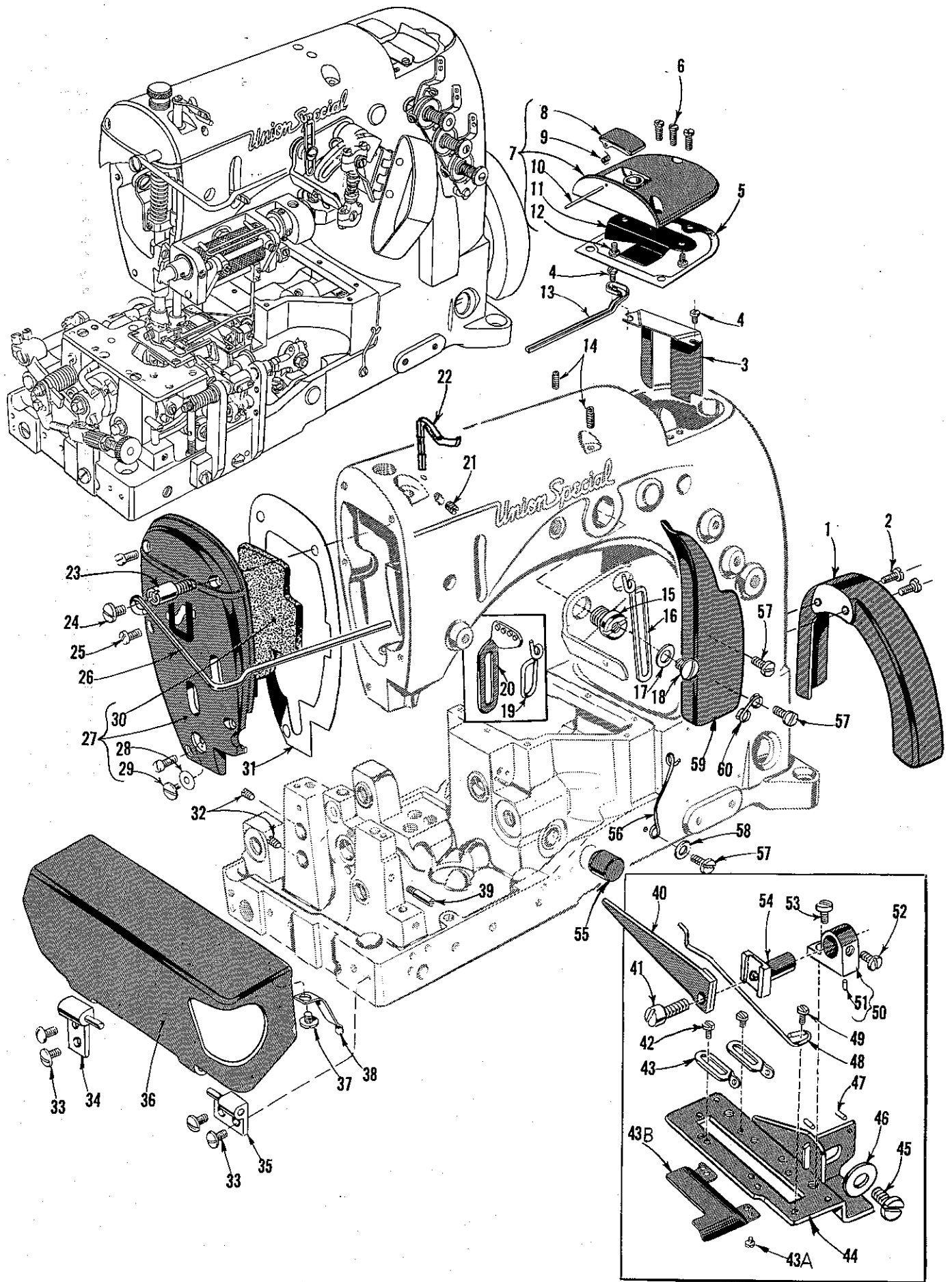

MAIN FRAME, CAST-OFF PLATE, MISCELLANEOUS COVERS AND PLATES

<u>Ref. No.</u>	<u>Part No.</u>	<u>Description</u>	<u>Amt. Req.</u>
1	B21375 AH	Belt Guard -----	1
2	93	Screw -----	2
3	52882 Y	Baffle Plate -----	1
4	90	Screw -----	2
5	52882 P	Gasket -----	1
6	22541 B	Screw -----	3
7	52882 AD	Chamber Cover -----	1
8	39582 L	Oil Cap -----	1
9	52882 AC	Oil Cap Torsion Spring -----	1
10	50-789 Blk.	Oil Cap Hinge Pin -----	1
11	52882 AA	Oil Drip Plate -----	1
12	90	Screw -----	2
13	51282 AE	Needle Lever Bearing Oiler -----	1
14	719	Screw, for Nos. 51150 and 51250 E, for Styles 52700 BK, BL, BM, BN, BP -----	2
15	22889 A	Adapter Plug Screw -----	1
16	539	Needle Thread Eyelet, for Styles 52700 BR, BT, BV -----	1
-	539	Needle Thread Eyelet, for Styles 52700 BS, BU -----	2
17	20	Washer -----	1
18	22848	Screw -----	1
19	51758	Needle Thread Eyelet, for Styles 52700 BK, BL, BN, BP -----	1
20	51858	Needle Thread Eyelet, for Style 52700 BM -----	1
21	95	Screw -----	1
22	52970 T	Take-up Wire, for Styles 52700 BK, BL, BN, BP -----	1
-	57770	Take-up Wire, for Styles 52700 BR, BS, BT, BU, BV -----	1
23	52782 C	Stud, for Styles 52700 BR, BS, BT, BU, BV -----	1
24	22581	Screw, for Styles 52700 BR, BS, BT, BU, BV -----	1
25	22569 B	Screw, for Styles 52700 BR, BS, BT, BU, BV -----	3
26	52778 X	Tape Lead-in Wire, for Styles 52700 BR, BS, BT, BU, BV -----	1
27	52782 D	Head Cover, for Styles 52700 BR, BS, BT, BU, BV -----	1
28	52882 W	Gasket -----	1
29	22542	Screw -----	1
30	51282 AC	Felt Liner -----	1
31	51282 Z	Head Cover Gasket, for Styles 52700 BR, BS, BT, BU, BV -----	1
32	22597	Screw, for Nos. 51435 B and 52835 U, for Styles 52700 BT, BU -----	2
33	22848	Screw -----	4
34	57885 B	Hinge Bracket, rear, for Styles 52700 BR, BS, BT, BU, BV -----	1
35	57885	Hinge Bracket, front, for Styles 52700 BR, BS, BT, BU, BV -----	1
36	51285 B	End Cover, for Styles 52700 BT, BU -----	1
-	52985	End Cover, for Styles 52700 BR, BS, BV -----	1
37	22711	Screw, for Styles 52700 BR, BS, BT, BU, BV -----	1
38	52885 L	End Cover Spring, for Styles 52700 BR, BS, BT, BU, BV -----	1
39	22799 M	Screw, for Styles 52700 BR, BS, BT, BU, BV -----	1
40	52904 B	Retaining Finger -----	1
41	22516	Screw -----	1
42	73 A	Screw -----	2
43	52958 D	Looper Thread Eyelet -----	2
43A	22798	Screw -----	2
43B	52994 B	Oil Guard, for Styles 52700 BK, BL, BM, BN, BP -----	1
44	52957 C	Cast-off Support Plate -----	1
45	22528	Screw -----	1
46	21657 E	Washer -----	1
47	50-216 Blk.	Dowel Pin -----	2
48	52904 G	Cast-off Wire -----	1
49	73 A	Screw -----	1
50	52904 E	Retaining Finger Support Bracket -----	1
51	50-216 Blk.	Dowel Pin -----	1
52	87 U	Screw -----	1
53	22768	Screw -----	1
54	52804 E	Retaining Finger Support -----	1
55	52942 Y	Looper Rocker Shaft Synchronizing Stud -----	1
56	52958 B	Frame Looper Thread Eyelet -----	1
57	98 A	Screw -----	3
58	20	Washer -----	1
59	51291 A	Looper Thread Guard -----	1
60	52 A	Looper Thread Eyelet -----	1

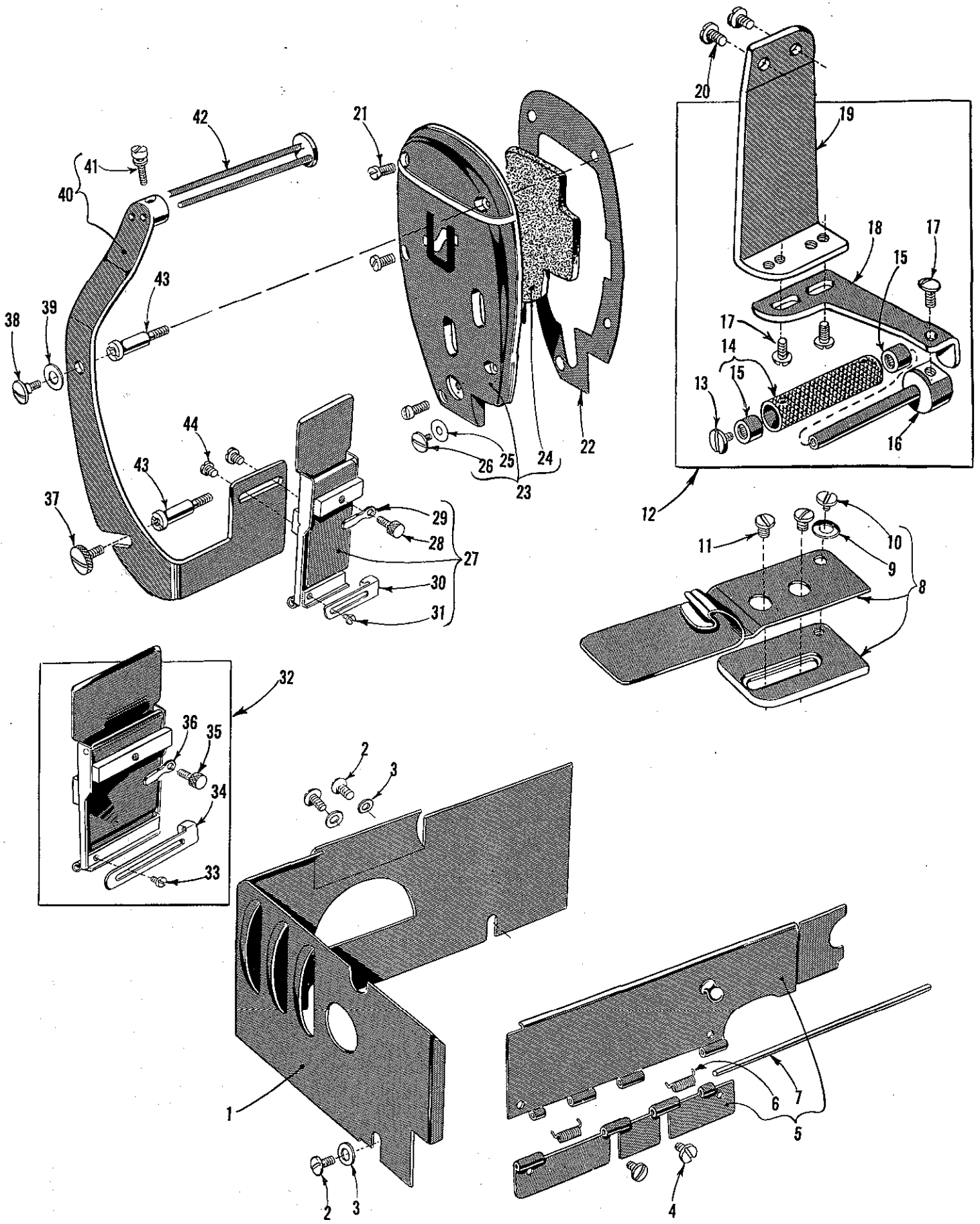

ELASTIC TENSION PARTS, MISCELLANEOUS COVERS AND ATTACHMENTS

<u>Ref. No.</u>	<u>Part No.</u>	<u>Description</u>	<u>Amt. Req.</u>
1	51282 AH	Oil Shield, end and back, for Styles 52700 BK, BL, BM, BN, BP-----	1
2	22848	Screw-----	3
3	20	Washer-----	3
4	25 S	Screw-----	2
5	51282 AJ	Hinged Oil Shield, front, for Styles 52700 BK, BL, BM, BN-----	1
6	51282 AK	Spring-----	2
7	52978 G	Hinge Pin-----	1
8	23405 M	Folder, 1/16 inch capacity, 1/8 inch fold upwardly, for Style 52700 BM-----	1
	23405 T	Folder, 1/16 inch capacity, 1/8 inch fold upwardly, for Styles 52700 BN, BP-----	1
	23405 U	Folder, 5/64 inch capacity, 3/16 inch fold upwardly, for Style 52700 BV-----	1
9	12957 E	Spring Washer-----	1
10	22726	Screw-----	1
11	25 C	Screw-----	2
12	23307 J	Elastic Guide Roller and Bracket Assembly, for Style 52700 BP-----	1
13	22542	Screw-----	1
14	23307 K	Elastic Guide Roll-----	1
15	660-274	Needle Bearing-----	2
16	23307 L	Elastic Guide Roll Shaft-----	1
17	22848	Screw-----	3
18	23307 M	Guide Roll Shaft Arm-----	1
19	23307 N	Bracket-----	1
20	22848	Screw-----	2
21	22569 B	Screw for Styles 52700 BK, BL, BP-----	5
	22569 B	Screw for Styles 52700 BM, BN-----	3
22	51282 Z	Gasket, for Styles 52700 BK, BL, BM, BN, BP-----	1
23	51282 Y	Head Cover, for Styles 52700 BK, BL, BM, BN, BP-----	1
24	51282 AC	Felt Liner-----	1
25	52882 W	Gasket-----	1
26	22542	Screw-----	1
27	23306 Z	Strip Guide and Tension, complete, 1/4 inch to 1 1/4 inch wide strips, for Style 52700 BN-----	1
28	22703	Screw-----	1
29	23306 AF	Tension Adjusting Nut-----	1
30	23306 T	Adjustable Strip Guide-----	1
31	25 B	Screw-----	1
32	23306 AE	Strip Guide and Tension, complete, 3/8 inch to 2 inches wide strips, for Style 52700 BM-----	1
33	25 B	Screw-----	1
34	23306 W	Adjustable Strip Guide-----	1
35	22703	Screw-----	1
36	23306 AF	Tension Adjusting Nut-----	1
37	22837	Thumb Screw, for Styles 52700 BM, BN-----	1
38	22504 C	Screw, for Styles 52700 BM, BN-----	1
39	12957 E	Spring Washer, for Styles 52700 BM, BN-----	1
40	23306 AA	Strip Guide and Tension Assembly Mounting Bracket, for Styles 52700 BM, BN-----	1
41	22568	Screw-----	1
42	23306 A	Frame Border Guide, for Styles 52700 BM, BN-----	1
43	52782 C	Stud, for Styles 52700 BM, BN-----	2
44	25 CC	Screw, for Styles 52700 BM, BN-----	2

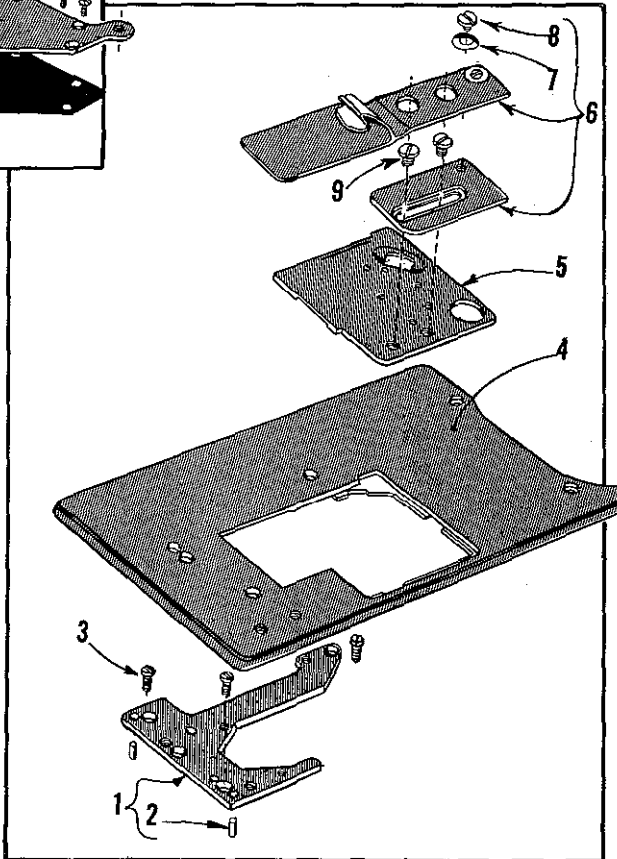
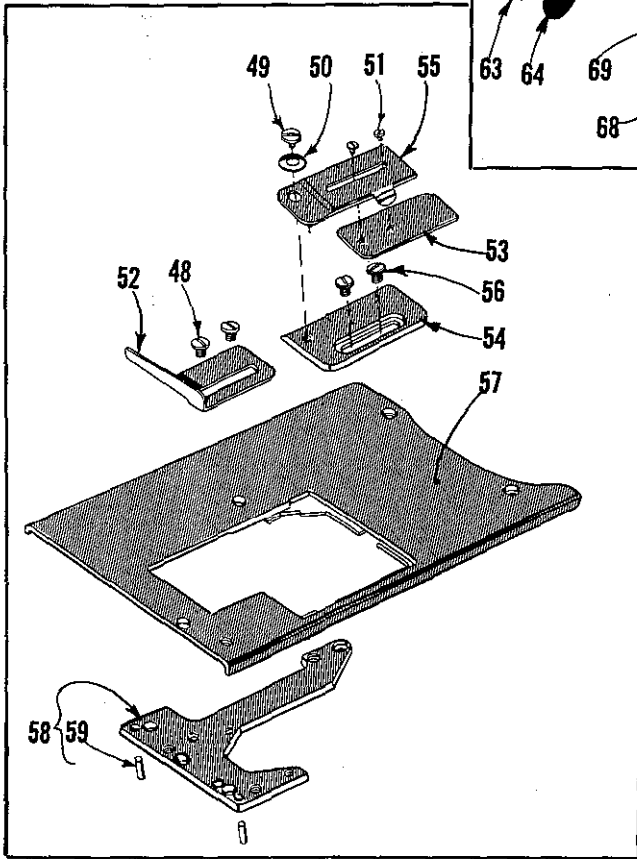
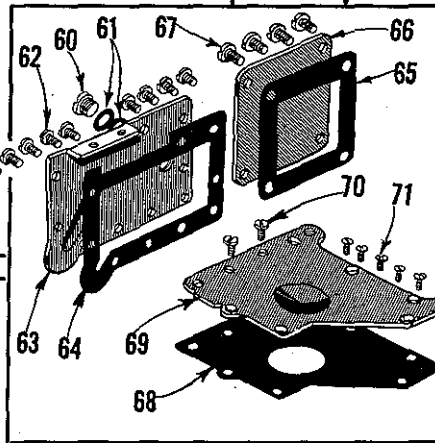
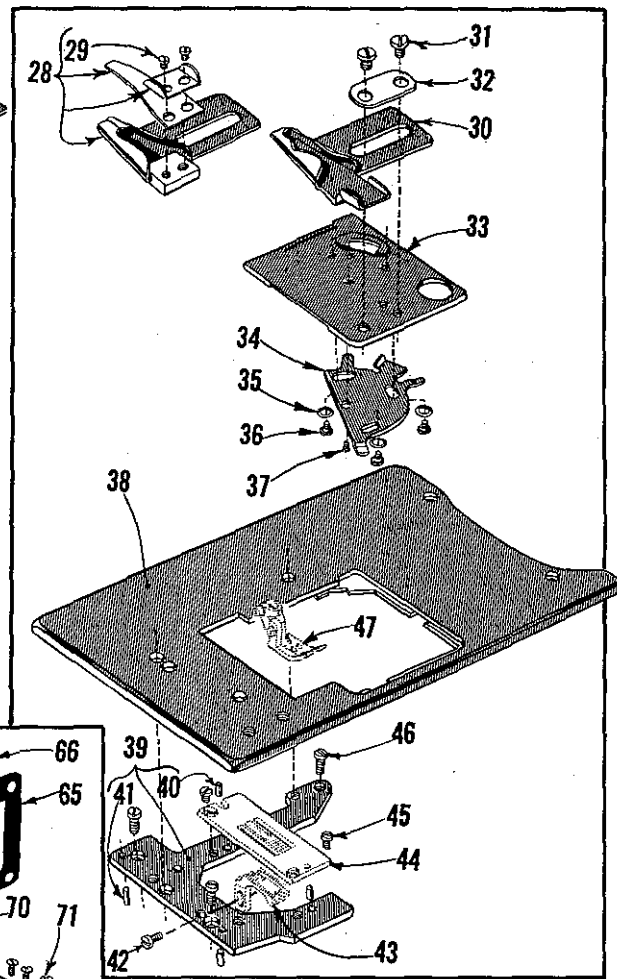
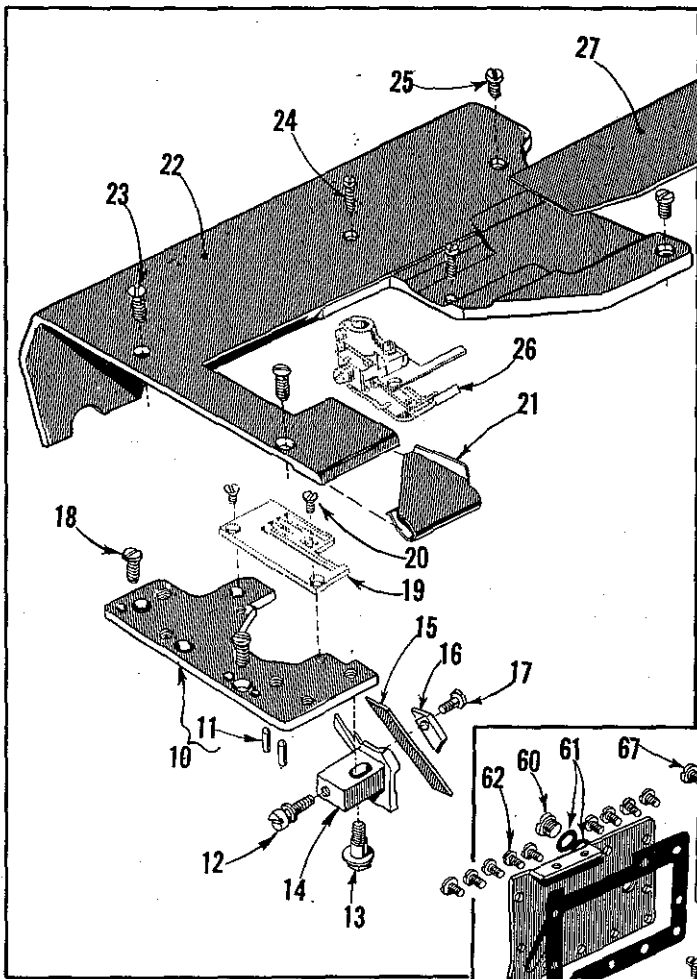

CLOTH PLATES, CLOTH PLATE COVERS, MISCELLANEOUS COVERS AND ATTACHMENTS

Ref. No.	Part No.	Description	Amt. Req.
1	51280 A	Throat Plate Support, for Styles 52700 BM, BN, BP	1
2	51280 J	Dowel Pin	2
3	22839	Screw, for throat plate support on Styles 52700 BM, BN, BP, BV	3
4	51301 D	Cloth Plate, for Styles 52700 BM, BN, BP	1
5	51281 T-219	Cloth Plate Cover, for Styles 52700 BM, BN, BP, BV	1
6	23405 M	Folder, 1/16 inch capacity, 1/8 inch fold upwardly, for Style 52700 BM	1
	23405 T	Folder, 1/16 inch capacity, 1/8 inch fold upwardly, for Styles 52700 BN, BP	1
7	12957 E	Spring Washer	1
8	22726	Screw	1
9	25 C	Screw	2
10	52980 A	Throat Plate Support, for Styles 52700 BR, BS, BT, BU	1
11	51280 J	Dowel Pin	2
12	22568	Screw	1
13	35766	Screw	1
14	52750 L	Lower Knife Block, for Styles 52700 BR, BS, BT, BU without improved trimming mechanism	1
* -	52750 C	Lower Knife Block, for Styles 52700 BR, BS, BT, BU with improved trimming mechanism	1
15	52949	Lower Knife, for Styles 52700 BR, BS, BT, BU without improved trimming mechanism	1
* -	52749 A	Lower Knife, for Styles 52700 BR, BS, BT, BU with improved trimming mechanism	1
16	52350 A	Lower Knife Holder Block, for Styles 52700 BR, BS, BT, BU	1
17	22588 A	Screw	1
18	22839	Screw, for throat plate support on Styles 52700 BR, BS, BT, BU	2
19		Throat Plate (See Pages 33, 35, 39, 41)	1
20	87	Screw, for throat plate on all Styles except 52700 BK, BL	2
21	52703 A	Edge Guide, for Styles 52700 BR, BS, BT, BU	1
22	52701 A	Cloth Plate, for Styles 52700 BR, BS, BT, BU without improved trimming mechanism	1
* -	52701 B	Cloth Plate, for Styles 52700 BR, BS, BT, BU with improved trimming mechanism	1
23	80	Screw, for cloth plate on Styles 52700 BK, BL, BM, BN, BP	3
	80	Screw, for cloth plate on Styles 52700 BR, BS, BT, BU, BV	2
24	22585 R	Screw, for Styles 52700 BR, BS, BT, BU	2
25	22839 C	Screw	2
26		Presser Foot (See Pages 33, 35, 39, 41)	1
27	52702	Cloth Plate Cover, for Styles 52700 BR, BS, BT, BU	1
28	23254	Folder, 7/8 inch wide strip, 3/8 inch finish, for No. 16 gauge Style 52700 BK	1
29	22561	Screw	2
30	23254 C	Folder, 11/16 inch wide strip, 1/4 inch finish, for No. 12 gauge Style 52700 BK	1
31	25 C	Screw	2
32	23425 V	Washer Plate, for Style 52700 BK	1
33	51281 P-207	Cloth Plate Cover, for Styles 52700 BK, BL	1
34	51281 AC	Cloth Plate Cover Spring, for Styles 52700 BK, BL, BM, BN, BP, BV	1
35	35772 H	Washer, for Styles 52700 BK, BL, BM, BN, BP, BV	3
36	22760 A	Screw, for Styles 52700 BK, BL, BM, BN, BP, BV	3
37	22845 B	Screw, for Styles 52700 BK, BL, BM, BN, BP, BV	1
38	53701	Cloth Plate, for Styles 52700 BK, BL	1
39	51480	Throat Plate Support, for Styles 52700 BK, BL	1
40	51280 K	Dowel Pin	2
41	51280 J	Dowel Pin	2
42	22528	Screw, for feed dog on all Styles except 52700 BT, BU	1
43		Feed Dog (See Pages 33, 35, 39, 41)	1
44		Throat Plate (See Pages 33, 35, 39, 41)	1
45	22570	Screw, for throat plate on Styles 52700 BK, BL	2
46	22839	Screw, for throat plate support on Styles 52700 BK, BL	3
47		Presser Foot (See Pages 33, 35, 39, 41)	1
48	25 C	Screw	2
49	22726	Screw, for Style 52700 BL	1
50	12957 E	Spring Washer, for Style 52700 BL	1
51	187 A	Screw, for Style 52700 BL	2
52	23440 D	Hemmer Scroll Guide, for Style 52700 BL	1
53	23440 C	Hemmer Blade, for Style 52700 BL	1
54	23440 A	Hemmer Base, for Style 52700 BL	1
55	23440 B	Hemmer Swing Arm, for Style 52700 BL	1
56	25 C	Screw	2
57	51101 R	Cloth Plate, for Style 52700 BV	1
58	52480	Throat Plate Support, for Style 52700 BV	1
59	51280 J	Dowel Pin	2
60	22733 B	Plug Screw	1
61	41394 A	Gasket	2
62	22848	Screw	9
63	52982 D	Oil Reservoir Back Cover	1
64	52982 E	Gasket	1
65	52882 U	Gasket	1
66	52882 AE	Crank Chamber Cover	1
67	22548	Screw	4
68	52882 K	Gasket	1
69	53782 B	Oil Reservoir Top Cover	1
70	22585 A	Screw	2
71	22524	Screw	7

* See Page 43 for repair parts applicable to Styles 52700 BR, BS, BT, BU with improved trimming mechanism.

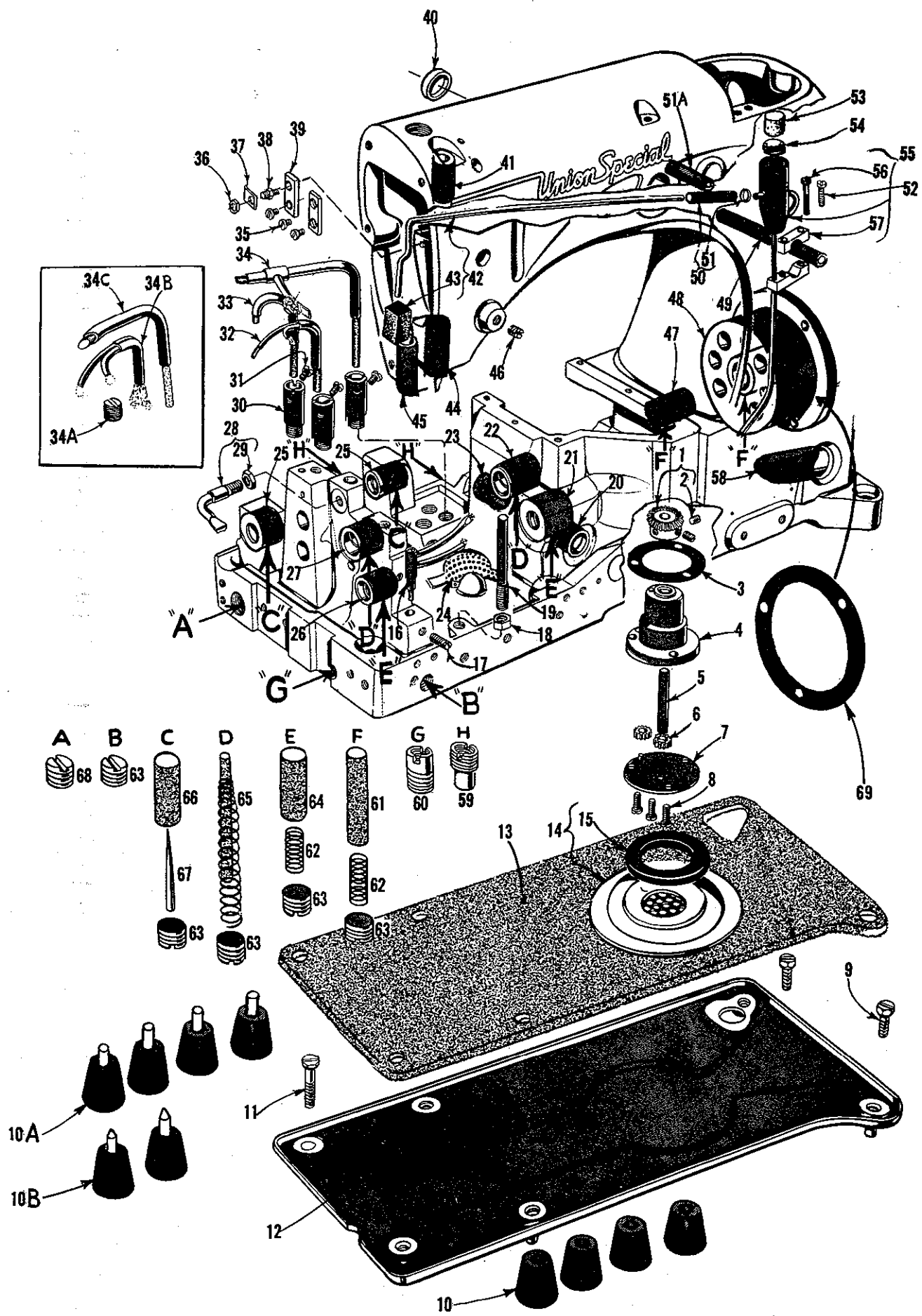

MAIN FRAME, BUSHINGS AND MISCELLANEOUS PARTS

<u>Ref. No.</u>	<u>Part No.</u>	<u>Description</u>	<u>Amt. Req.</u>
1	51493 BQ	Pump Driven Gear -----	1
2	531	Screw-----	2
3	643-127 Blk.	Gasket-----	1
4	51493 AG	Oil Pump Housing -----	1
5	51493 D	Oil Pump Driving Shaft -----	1
6	51493 E	Driving Shaft Gear -----	2
7	51493 AH	Oil Pump Housing Cover -----	1
8	22569 B	Screw -----	3
9	22823 A	Screw -----	2
10	51295 A	Mounting Isolator, for Styles 52700 BK, BL, BM, BN, BP-----	4
10A	39595	Mounting Isolator, for Styles 52700 BR, BS, BT, BU, BV -----	4
10B	51295 B	Mounting Isolator, for Styles 52700 BR, BS, BT, BU, BV -----	2
11	22823 B	Screw-----	1
12	51493 AY	Oil Pan Base Plate, for Styles 52700 BK, BL, BM, BN (4 point isolation) -----	1
	51493 BA	Oil Pan Base Plate, for Style 52700 BP (4 point isolation) -----	1
	51493 BB	Oil Pan Base Plate, for Styles 52700 BR, BS, BT, BU, BV (6 point isolation) -----	1
13	51493 BG	Base Plate Felt -----	1
14	51493 BH	Filter Cap Assembly -----	1
15	51493 BJ	Washer, sponge rubber -----	1
16	52894 AK	Oil Tube, for looper rocker and left ball -----	1
17	22560 B	Screw-----	1
18	258	Nut, for Styles 52700 BR, BS, BT, BU-----	1
19	51280 E	Throat Plate Support Pin, for Styles 52700 BR, BS, BT, BU -----	1
20	52942 W	Looper Drive Lever Shaft Bushing, front -----	1
21	52944 U	Looper Rocker Shaft Bushing, right -----	1
22	51290 T	Main Shaft Bushing, middle -----	1
23	52942 X	Looper Drive Lever Shaft Bushing, rear -----	1
24	51493 BK	Lint Filter Screen-----	1
25	52936	Feed Rocker Shaft Bushing, right and left -----	2
26	52944 T	Looper Rocker Shaft Bushing, left -----	1
27	52890 C	Main Shaft Bushing, left -----	1
28	660-136	Oil Tube, for feed crank link -----	1
29	258 A	Nut -----	1
30	52894 AB	Oil Tube Holder, for Styles 52700 BK, BL, BM, BN, BP-----	1
	52894 AB	Oil Tube Holder, for Styles 52700 BR, BS, BV-----	2
	52894 AB	Oil Tube Holder, for Styles 52700 BT, BU-----	3
31	90	Screw, for Styles 52700 BK, BL, BM, BN, BP-----	1
	90	Screw, for Styles 52700 BR, BS, BV-----	2
	90	Screw, for Styles 52700 BT, BU-----	3
32	52994 AC	Oil Tube, for Styles 52700 BR, BS, BT, BU -----	1
-	52794 H	Oil Tube, for Style 52700 BV-----	1
33	52894 AD	Oil Tube, for Styles 52700 BT, BU -----	1
34	52894 AE	Oil Tube, for Styles 52700 BT, BU -----	1
34A	22571 B	Plug Screw, for Styles 52700 BK, BL, BM, BN, BP, BR, BS, BV -----	1
34B thru 68		See following page	

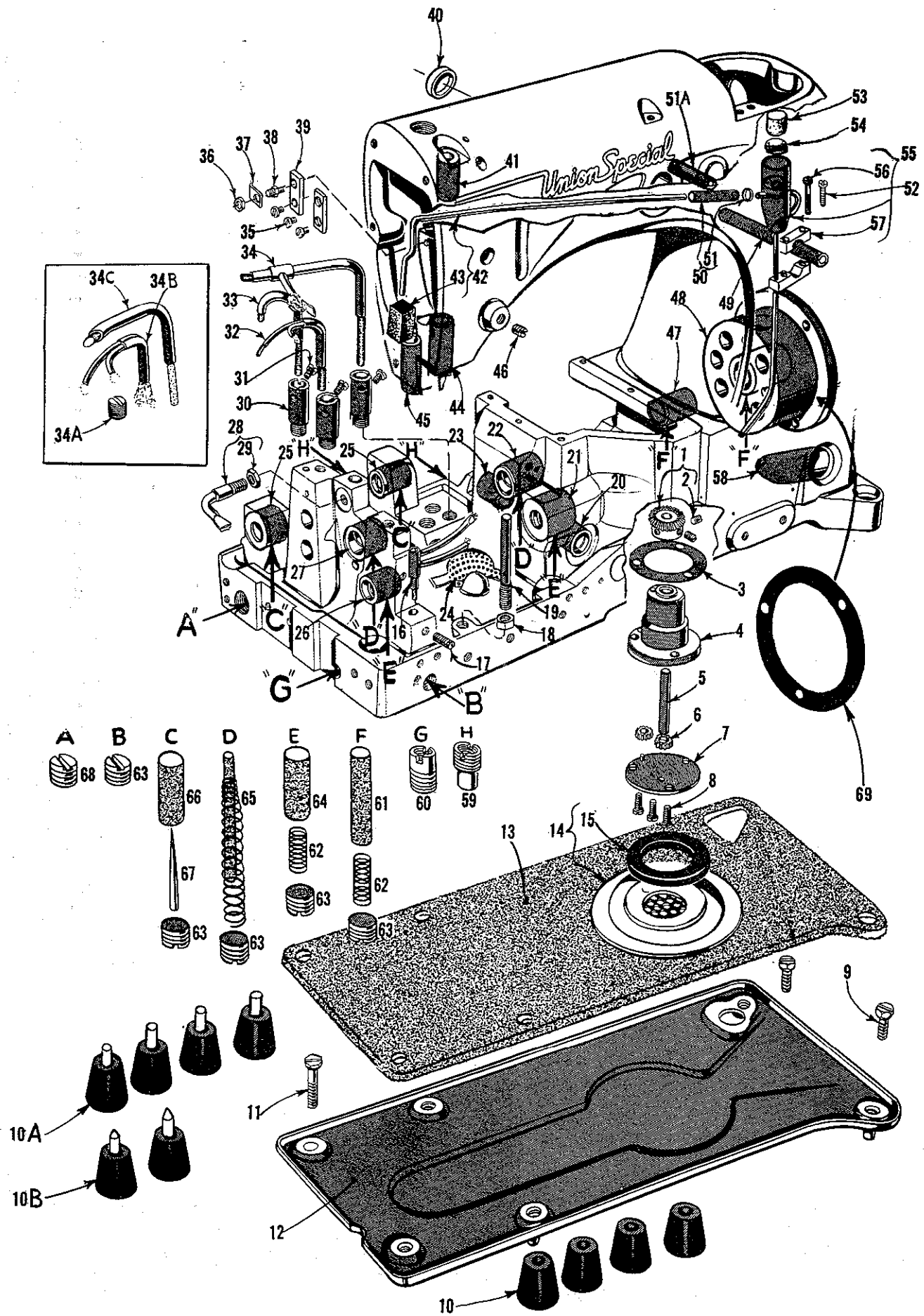

MAIN FRAME, BUSHINGS AND MISCELLANEOUS PARTS

<u>Ref. No.</u>	<u>Part No.</u>	<u>Description</u>	<u>Amt. Req.</u>
1 thru 34A		See preceding page	
34B	52794 G	Oil Tube, for feed lift and looper avoid eccentric, for Styles 52700 BK, BL, BM, BN, BP-----	1
34C	51193 S	Oil Tube, for feed lift eccentric, for Styles 52700 BR, BS, BV-----	1
35	22513	Screw-----	3
36	7947	Nut-----	1
37	51294 P	Oil Tube Clamp-----	1
38	51294 R	Screw-----	1
39	35731 A	Presser Bar Connecting Guide Plate-----	2
40	35761 D	Needle Lever Shaft Bushing Cap, for Styles 52700 BR, BS, BT, BU, BV-----	1
41	51254 C	Needle Bar Bushing, upper-----	1
42	51294 M	Oil Siphon Tube-----	1
43	666-214	Felt Lint Filter-----	1
44	51254 D	Needle Bar Bushing, lower-----	1
45	51257 AA	Presser Bar Bushing, lower-----	1
46	95	Plug Screw, for all Styles except 52700 BR, BS, BT, BU, BV-----	1
47	52890 C	Main Shaft Bushing, inner right-----	1
48	52891 B	Crankshaft Bearing Housing, including bushing-----	1
49	21657 X	Tension Release Lever Shaft Bushing-----	1
50	51294 Z	Oil Tube Connection-----	1
51	21212	Oil Siphon Connecting Locking Ring-----	1
51A	52883 R	Presser Foot Lifter Lever Bushing-----	1
52	22729 A	Screw-----	1
53	666-201	Felt Plug-----	1
54	666-209	Felt Disc-----	1
55	51294 U	Oil Siphon Assembly-----	1
56	22729 B	Screw-----	1
57	51294 K	Clamp, upper-----	1
58	50-648 Blk.	Lucite Oil Gauge-----	1
59	22889 C	Adaptor Plug Screw, for all Styles except 52700 BT, BU-----	2
60	22889 D	Adaptor Plug Screw, for all Styles except 52700 BT, BU-----	1
61	666-114	Oil Wick, for right main shaft bearing-----	2
62	35178 D	Spring-----	4
63	22571 A	Plug Screw, for all Styles except 52700 BT, BU-----	15
	22571 A	Plug Screw, for Styles 52700 BT, BU-----	18
64	666-65	Oil Wick, for looper rocker shaft-----	2
65	666-118	Oil Wick, for left main shaft bearing-----	2
66	666-111	Oil Wick, for feed rocker shaft-----	2
67	666-179	Wedge Pin-----	2
68	22539 H	Plug Screw-----	1
69	56390 E	Gasket, for crankshaft bearing housing-----	1

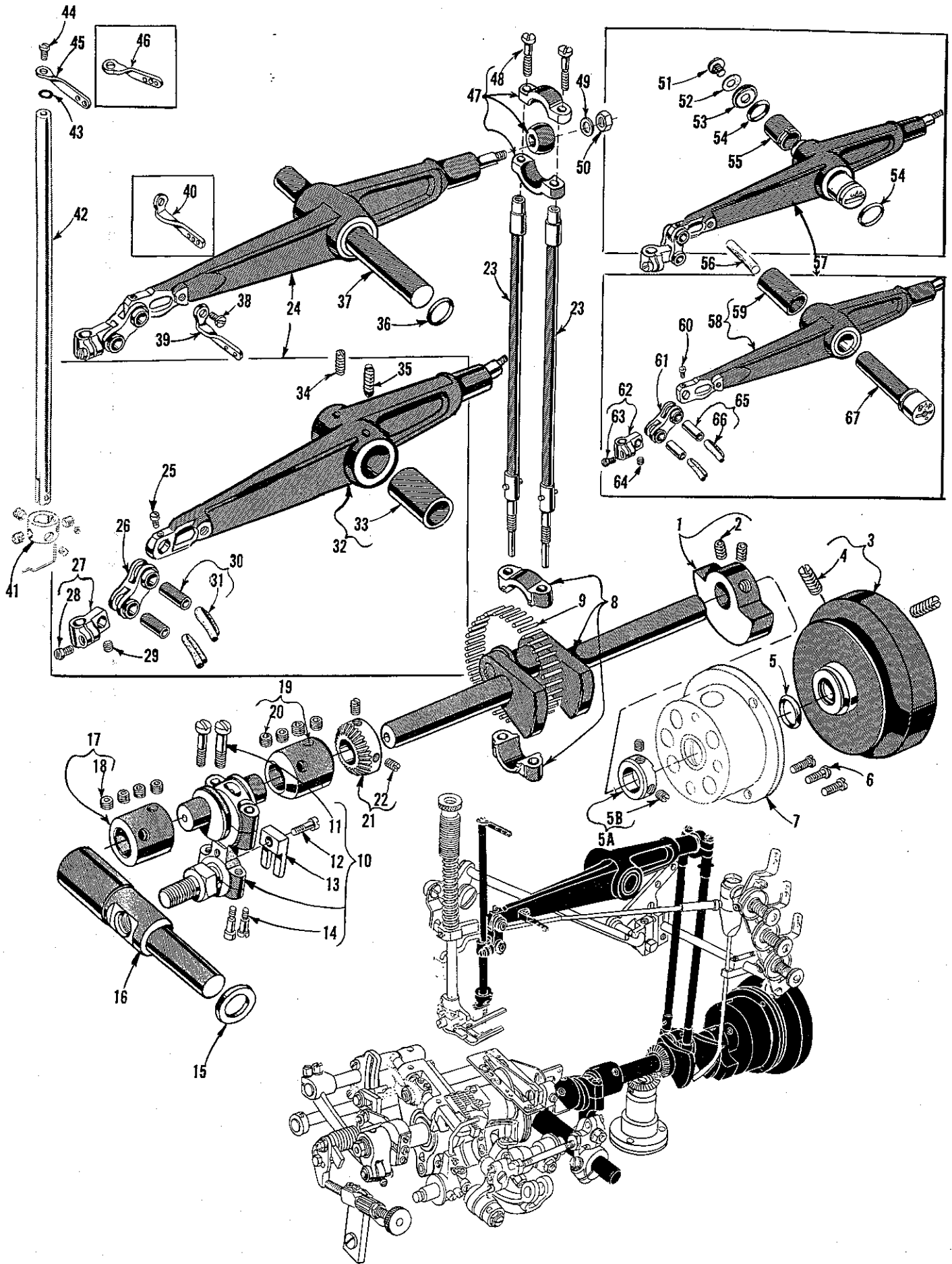

CRANKSHAFT, NEEDLE LEVER AND LOOPER DRIVING PARTS

Ref. No.	Part No.	Description	Amt. Req.
1	51247	Crankshaft Counterweight	1
2	22894 J	Screw	2
*3	51221 C	Pulley, for all Styles except 52700 BR, BS, BT, BU with improved trimming mechanism	1
4	22894 F	Screw	2
5	660-202	"O" Ring, for pulley	1
5A	51147	Thrust Collar	1
5B	95	Screw	2
6	22569 B	Screw	3
7	52891 B	Crankshaft Bearing Housing, including bushing	1
8	29476 JP	Crankshaft Assembly, .910 inch throw, marked "51222 J"	1
9	51216 M	Needle Bearing	28
10	29476 LE	Looper Driving Lever Crank Assembly, crank marked "D"	1
11	22587	Screw, upper	2
12	22729 D	Screw	1
13	51243 C	Ball Stud Guide	1
14	22559 A	Screw, lower	2
15	52951 C	Spacing Washer	1
16	52942 A	Looper Drive Lever Rocker Shaft	1
17	56343 D	Looper Drive Lever Crank Connection, left	1
18	22894 X	Screw	4
19	52943 L	Looper Drive Lever Crank Connection, right	1
20	22894 X	Screw	4
21	51493 BP	Pump Driving Gear	1
22	22560 B	Screw	2
23	51216 G	Needle Lever Connecting Rod	2
24	29348 V	Needle Lever Assembly, for Styles 52700 BR, BS, BT, BU, BV	1
25	77	Screw	1
26	56354 A	Needle Bar Link	1
27	51254 J	Needle Bar Connection	1
28	22562 A	Screw	1
29	22564	Screw	1
30	51054	Link Pin	2
31	666-149	Lubricating Felt	2
32	52715	Needle Lever	1
33	51250 A	Bushing	1
34	22591	Screw	1
35	HA81	Screw	1
36	660-202	Oil Seal Ring, for Styles 52700 BR, BS, BT, BU, BV	1
37	52750	Needle Lever Shaft, for Styles 52700 BR, BS, BT, BU, BV	1
38	22768	Screw	1
39	56458	Needle Lever Thread Eyelet, for Styles 52700 BK, BL, BN, BP, BR, BT, BV	1
40	56958	Needle Lever Thread Eyelet, for Styles 52700 BM, BS, BU	1
41		Needle Clamp Collar (See Page 31)	1
42		Needle Bar (See Page 31)	1
43	27-435 Blk.	Washer	1
44	22768	Screw	1
45	56458 A	Needle Bar Thread Eyelet, for Styles 52700 BK, BL, BN, BP, BR, BT, BV	1
46	56958 A	Needle Bar Thread Eyelet, for Styles 52700 BM, BS, BU	1
47	29066 R	Needle Lever Connecting Rod and Upper Bearing Assembly	1
48	22559 G	Screw	2
49	51216 N	Washer	1
50	51216 P	Nut	1
51	22586 R	Screw, for Styles 52700 BK, BL, BM, BN, BP	1
52	51250 F	Gasket, for Styles 52700 BK, BL, BM, BN, BP	1
53	51250 D	Washer, for Styles 52700 BK, BL, BM, BN, BP	1
54	660-212	Oil Seal Ring, for Styles 52700 BK, BL, BM, BN, BP	2
55	51150	Needle Lever Shaft Stop Collar, for Styles 52700 BK, BL, BM, BN, BP	1
56	666-170	Oil Wick	1
57	29348 P	Needle Lever Assembly, for Styles 52700 BK, BL, BM, BN, BP	1
58	51215 J	Needle Lever	1
59	51250 A	Bushing	1
60	77	Screw, for upper link pin	1
61	56354 A	Needle Bar Link	1
62	51254 J	Needle Bar Connection	1
63	22562 A	Screw	1
64	22564	Screw	1
65	51054	Link Pin	2
66	666-149	Lubricating Felt	2
67	51250 E	Needle Lever Stud	1

* See Page 43 for comparable repair parts applicable to Styles 52700 BR, BS, BT, BU with improved trimming mechanism.

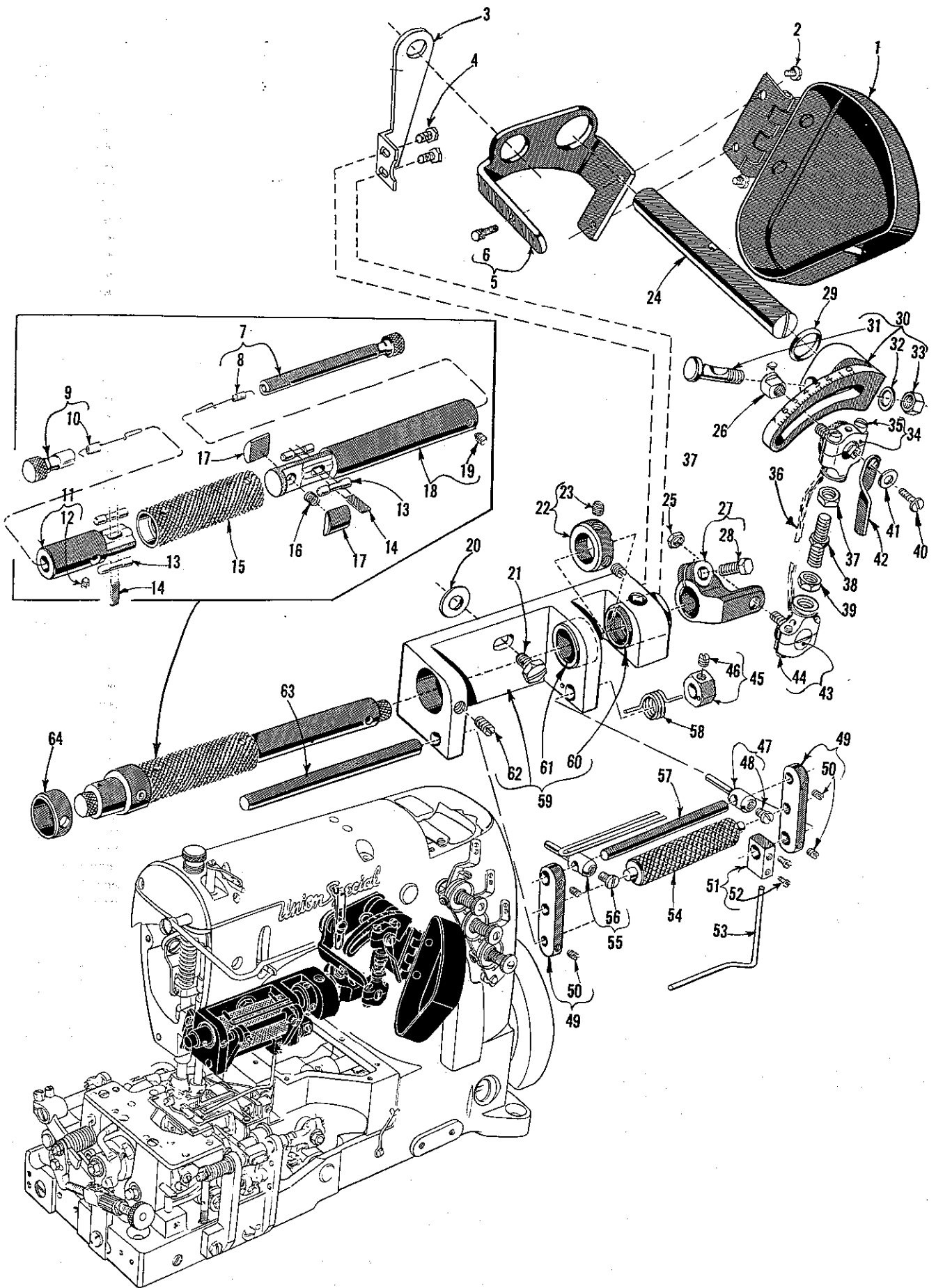

FOR STYLES 52700 BR, BS, BT, BU, BV ONLY

UPPER METERING DEVICE AND METERING DEVICE DRIVING PARTS

<u>Ref. No.</u>	<u>Part No.</u>	<u>Description</u>	<u>Amt. Req.</u>
1	52777 AA	Clutch Drive Lever Cover -----	1
2	87 U	Screw -----	2
3	52777 AG	Clutch Frame Mounting Bracket -----	1
4	79048	Screw -----	2
5	52777 AC	Cover Mounting Plate -----	1
6	22703	Screw -----	1
7	52777 V	Torsion Rod, right -----	1
8	52777 X	Torsion Spring -----	1
9	52777 W	Torsion Rod, left -----	1
10	52777 AE	Torsion Spring -----	1
11	52777 S	Clutch Lock Shaft -----	1
12	22743	Screw -----	1
13	52777 Z	Clutch Roller -----	4
14	52777 Y	Torsion Rod Pressure Plate -----	2
15	52777 R	Clutch Barrel -----	1
16	52777 U	Brake Spring -----	1
17	52777 T	Fiber Brake -----	2
18	52776 P	Clutch Drive Shaft -----	1
19	22743	Screw -----	1
20	40-181	Washer -----	1
21	22882	Screw -----	1
22	9660 B	Collar -----	1
23	98	Screw -----	2
24	52750	Needle Lever Shaft -----	1
25	12982	Nut -----	1
26	52776 W	Elastic Metering Pointer -----	1
27	52776 G	Clutch Rocker Shaft Lever -----	1
28	22852	Screw -----	1
29	660-202	Oil Seal Ring -----	1
30	52776 R	Clutch Drive Lever -----	1
31	55235 D	Stud -----	1
32	6042 A	Washer -----	1
33	55235 E	Nut -----	1
34	52776 T	Ball Joint, upper -----	1
35	22729 C	Screw -----	2
36	CL21	Oil Wick -----	1
37	43242 P	Nut -----	1
38	43242 N	Connecting Rod -----	1
39	15037 A	Nut -----	1
40	22804	Screw -----	1
41	53678 N	Washer -----	1
42	52776 V	Release Lever -----	1
43	52776 L	Ball Joint, lower -----	1
44	22729 C	Screw -----	2
45	52778 T	Tension Adjusting Collar -----	1
46	89	Screw -----	1
47	52778 D	Strip Guide -----	1
48	22562	Screw -----	1
49	52778 N	Strip Tension Link -----	2
50	22733	Screw -----	2
51	52778 U	Tape Guide Block -----	1
52	22738	Screw -----	2
53	52778 V	Tape Guide Wire -----	1
54	52778 F	Strip Tension Roller -----	1
55	52778 W	Tape Lead-in Guide -----	1
56	22562	Screw -----	1
57	52778 S	Strip Guide Shaft -----	1
58	52778 P	Strip Tension Link Spring -----	1
59	52777 AF	Clutch Frame -----	1
60	52777 M	Bushing -----	1
61	52777 N	Bushing -----	1
62	22560 A	Screw -----	1
63	52778 R	Tension Shoe Pivot Shaft -----	1
64	52777 P	Adjustable Bushing -----	1

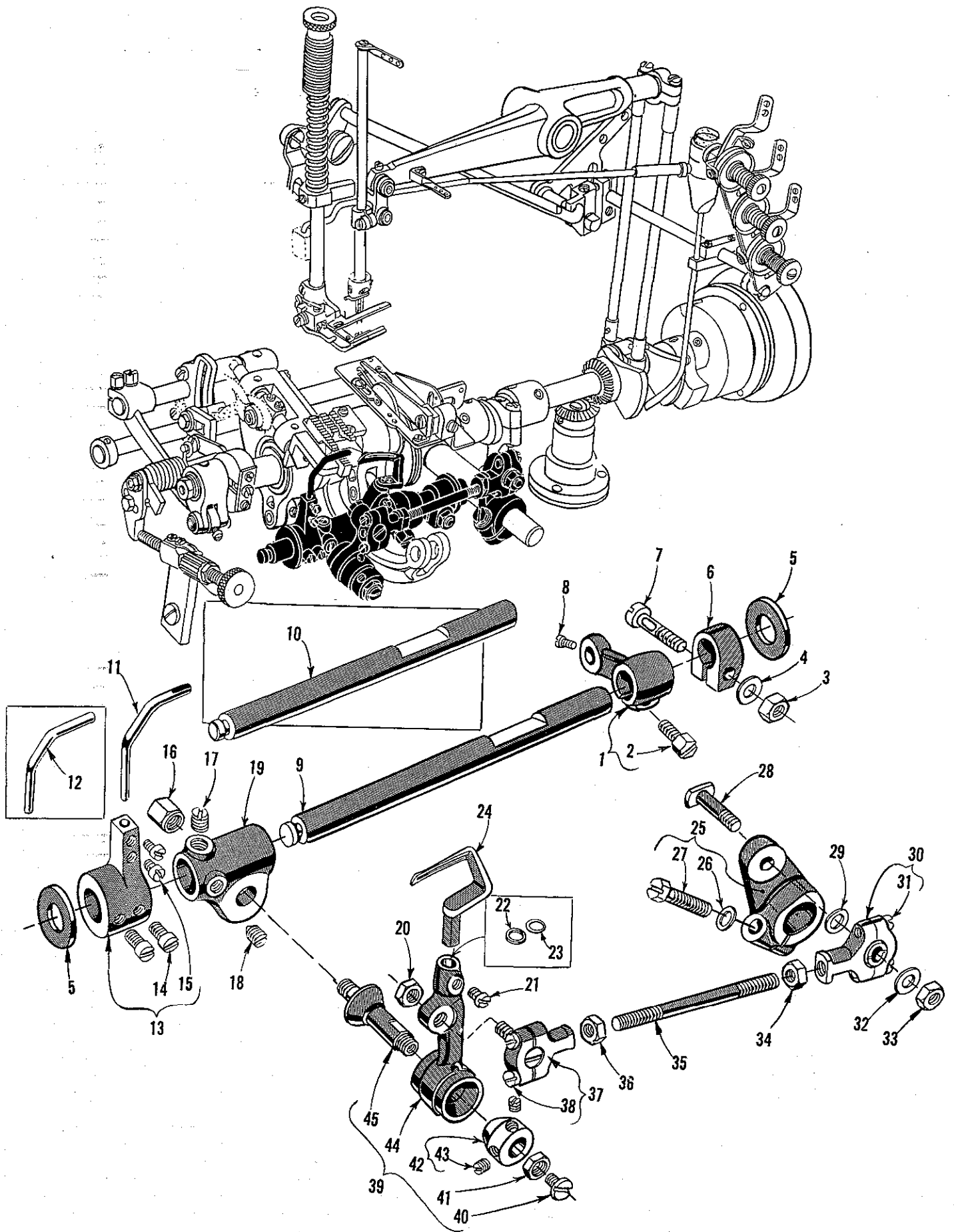

LOOPER ROCKER AND CONNECTING ROD PARTS

Ref. No.	Part No.	Description	Amt. Req.
* 1	51244 B	Looper Rocker Shaft Arm, for all Styles except 52700 BR, BS, BT, BU with improved trimming mechanism -----	1
2	22519 H	Screw -----	1
3	18	Nut -----	1
4	51216 N	Washer -----	1
5	51244 L	Thrust Washer -----	2
6	51244 N	Looper Rocker Shaft Collar -----	1
7	55244 G	Looper Rocker Shaft Collar Stud -----	1
8	22768	Screw -----	1
9	52744	Looper Rocker Shaft, for Style 52700 BP -----	1
10	51144	Looper Rocker Shaft, for all Styles except 52700 BP -----	1
11	52725 A	Looper Needle Guard, for Styles 52700 BR, BS, BT, BU, BV -----	1
12	52825 C	Looper Needle Guard, for Styles 52700 BK, BL, BM, BN, BP -----	1
13	52825 D	Needle Guard Holder -----	1
14	33174 B	Screw -----	2
15	22563	Screw -----	2
16	51246	Looper Rocker Stud Nut -----	1
17	98	Screw, for all Styles except 52700 BR, BS, BT, BU with improved trimming mechanism -----	1
18	96	Screw -----	1
*19	52444 B	Looper Rocker Frame, for all Styles except 52700 BR, BS, BT, BU with improved trimming mechanism -----	1
20	18	Nut -----	1
21	73	Screw -----	1
22	21210	Looper Collar, .040 inch thick, for Style 52700 BL -----	1
23	21210 A	Looper Collar, .020 inch thick, for Style 52700 BK -----	1
24	52708 B	Looper -----	1
25	52942 P	Looper Drive Lever -----	1
26	51242 M	Washer -----	1
27	22882 A	Screw -----	1
28	52942 R	Looper Drive Lever Stud -----	1
29	41355 U-4	Shim, .004 inch thick (as required) -----	
	41355 U-5	Shim, .005 inch thick (as required) -----	
	41355 U-6	Shim, .006 inch thick (as required) -----	
	41355 U-7	Shim, .007 inch thick (as required) -----	
	41355 U-8	Shim, .008 inch thick (as required) -----	
	41355 U-9	Shim, .009 inch thick (as required) -----	
30	52941 D	Looper Connecting Rod Ball Joint, right -----	1
31	97 A	Screw -----	2
32	20	Washer -----	1
33	18	Nut, right thread -----	1
34	18	Nut, right thread -----	1
35	39141	Looper Connecting Rod -----	1
36	269	Nut, left thread -----	1
37	52841 A	Looper Connecting Rod Ball Joint, left -----	1
38	22729 C	Screw -----	2
39	29192 T	Looper Rocker Assembly, for Styles 52700 BK, BL, BM, BN, BP, BT, BU -----	1
	29192	Looper Rocker Assembly, for Styles 52700 BR, BS, BV -----	1
40	22829	Lock Nut Screw -----	1
41	258 A	Lock Nut -----	1
42	15465 F	Looper Rocker Cone -----	1
43	22894 W	Screw -----	2
44	52813	Looper Rocker, for Styles 52700 BK, BL, BM, BN, BP, BT, BU -----	1
	51213	Looper Rocker, for Styles 52700 BR, BS, BV -----	1
45	51745	Looper Rocker Cone Stud -----	1

* See Page 43 for comparable repair parts applicable to Styles 52700 BR, BS, BT, BU with improved trimming mechanism.

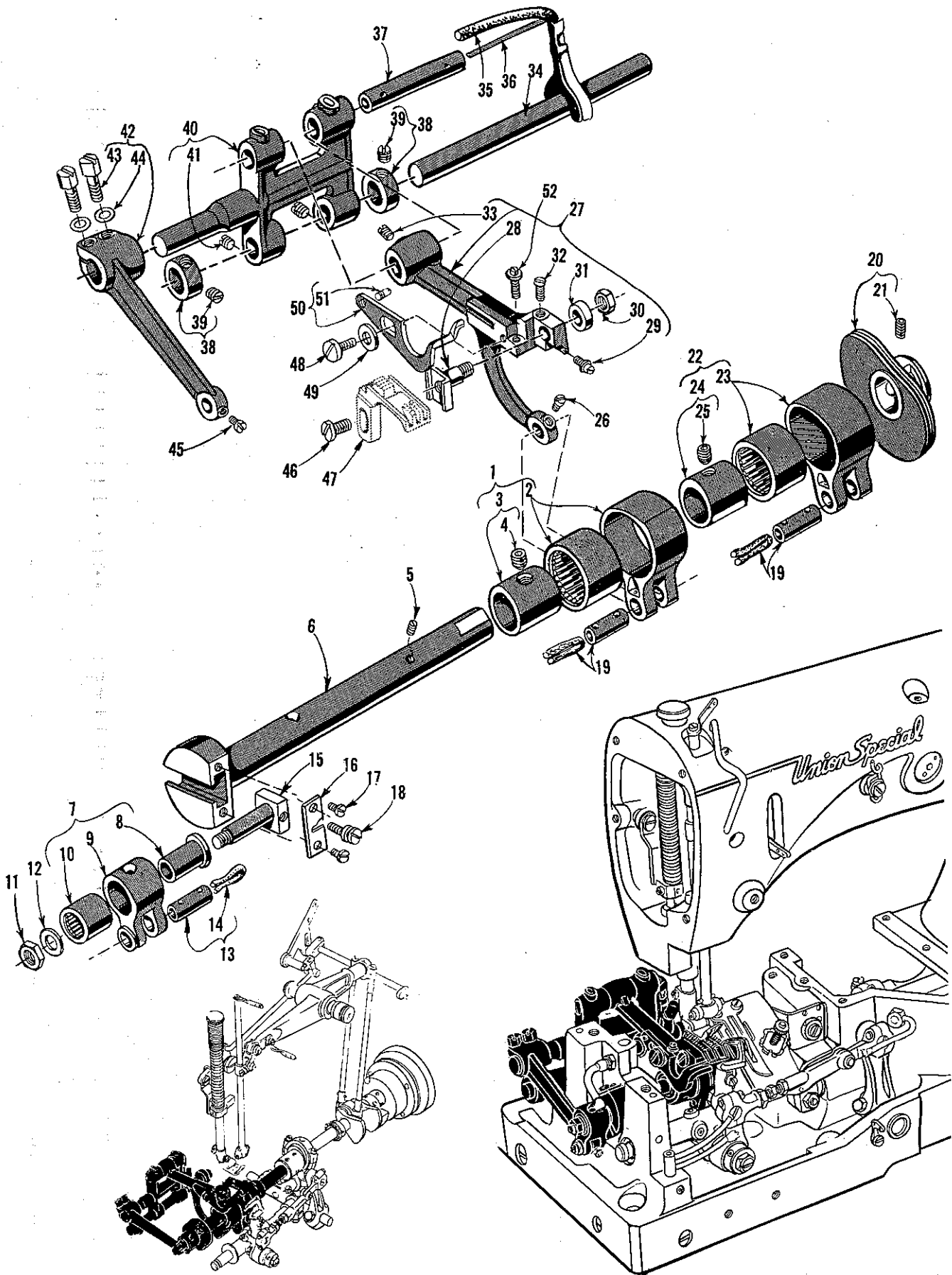

MAIN SHAFT AND FEED MECHANISM

<u>Ref. No.</u>	<u>Part No.</u>	<u>Description</u>	<u>Amt. Req.</u>
1	29476 DV	Feed Lift Eccentric Assembly-----	1
2	51145 A	Eccentric Bearing -----	1
3	51406	Eccentric, .062 inch throw -----	1
4	22894 D	Screw-----	1
5	22801	Screw -----	1
6	52922 C	Main Shaft, for Styles 52700 BK, BL, BM, BN, BP -----	1
	52722	Main Shaft, for Styles 52700 BR, BS, BV without improved trimming mechanism -----	1
* -	52722 E	Main Shaft, for Styles 52700 BR, BS with improved trimming mechanism -----	1
	52722 B	Main Shaft, for Styles 52700 BT, BU without improved trimming mechanism -----	1
* -	52722 D	Main Shaft, for Styles 52700 BT, BU with improved trimming mechanism-----	1
7	51236 E	Feed Crank Link, complete -----	1
8	51236 F	Feed Crank Link Ferrule -----	1
9	51236 D	Feed Crank Link -----	1
10	660-169	Needle Bearing -----	1
11	269	Nut, left thread-----	1
12	20	Washer -----	1
13	51054	Link Pin -----	1
14	666-149	Oil Wick -----	1
15	51236 G	Feed Crank Stud -----	1
16	51236 B	Feed Crank Stud Cap -----	1
17	22768	Screw-----	2
18	22795	Screw-----	1
19	51236 A	Link Pin -----	2
20	52923 D	Take-up -----	1
21	22580 D	Screw, set -----	2
*22	29476 DV	Looper Avoid Eccentric Assembly, for Styles 52700 BL, BM, BN, BP, BR, BS, BV without improved trimming mechanism -----	1
-	29476 DX	Looper Avoid Eccentric Assembly, for Style 52700 BK-----	1
* -	29476 JN	Looper Avoid Eccentric Assembly, for Styles 52700 BT, BU without improved trimming mechanism -----	1
23	51145 A	Eccentric Bearing -----	1
24	51406	Eccentric, .062 inch throw, for 29476 DV, JN -----	1
	51306	Eccentric, .072 inch throw, for 29476 DX -----	1
25	22894 D	Screw, for 29476 DV, DX -----	1
	22894 T	Screw, for 29476 JN -----	1
26	77	Screw-----	1
27	51134	Feed Bar, for Styles 52700 BK, BL, BM, BN, BP, BR, BS, BV-----	1
28	56334 E	Feed Dog Holder -----	1
29	22863	Feed Dog Holder Adjusting Screw -----	1
30	258 A	Check Nut -----	1
31	51134 J	Feed Dog Holder Washer -----	1
32	538	Feed Dog Height Adjusting Screw -----	1
33	22560 B	Screw-----	1
34	8	Feed Rocker Shaft -----	1
35	51134 P	Lubricating Felt, for Styles 52700 BK, BL, BM, BN, BP, BR, BS, BV-----	1
36	51134 R	Lubricating Felt Guard, for Styles 52700 BK, BL, BM, BN, BP, BR, BS, BV -----	1
37	51134 C	Feed Bar Shaft-----	1
38	482	Collar -----	2
39	98	Screw-----	1
40	51235	Feed Rocker, for Styles 52700 BK, BL, BM, BN, BP, BR, BS, BV -----	1
41	98	Screw -----	2
42	51235 A	Feed Rocker Arm, for Styles 52700 BK, BL, BM, BN, BP, BR, BS, BV -----	1
43	22519 C	Screw-----	2
44	51235 G	Washer -----	2
45	77	Screw-----	1
46	22528	Screw, for feed dog on Styles 52700 BK, BL, BM, BN, BP, BR, BS, BV-----	1
47		Feed Dog (See Pages 33, 35, 39, 41)-----	1
48	22585 B	Screw-----	1
49	51225 W	Washer -----	1
50	52725	Needle Guard, for Styles 52700 BK, BL, BM, BN, BP, BR, BS, BV -----	1
51	22801	Pivot Screw -----	1
52	22834	Needle Guard Adjusting Screw, for Styles 52700 BK, BL, BM, BN, BP, BR, BS, BV-----	1

* See Page 43 for repair parts applicable to Styles 52700 BR, BS, BT, BU with improved trimming mechanism.

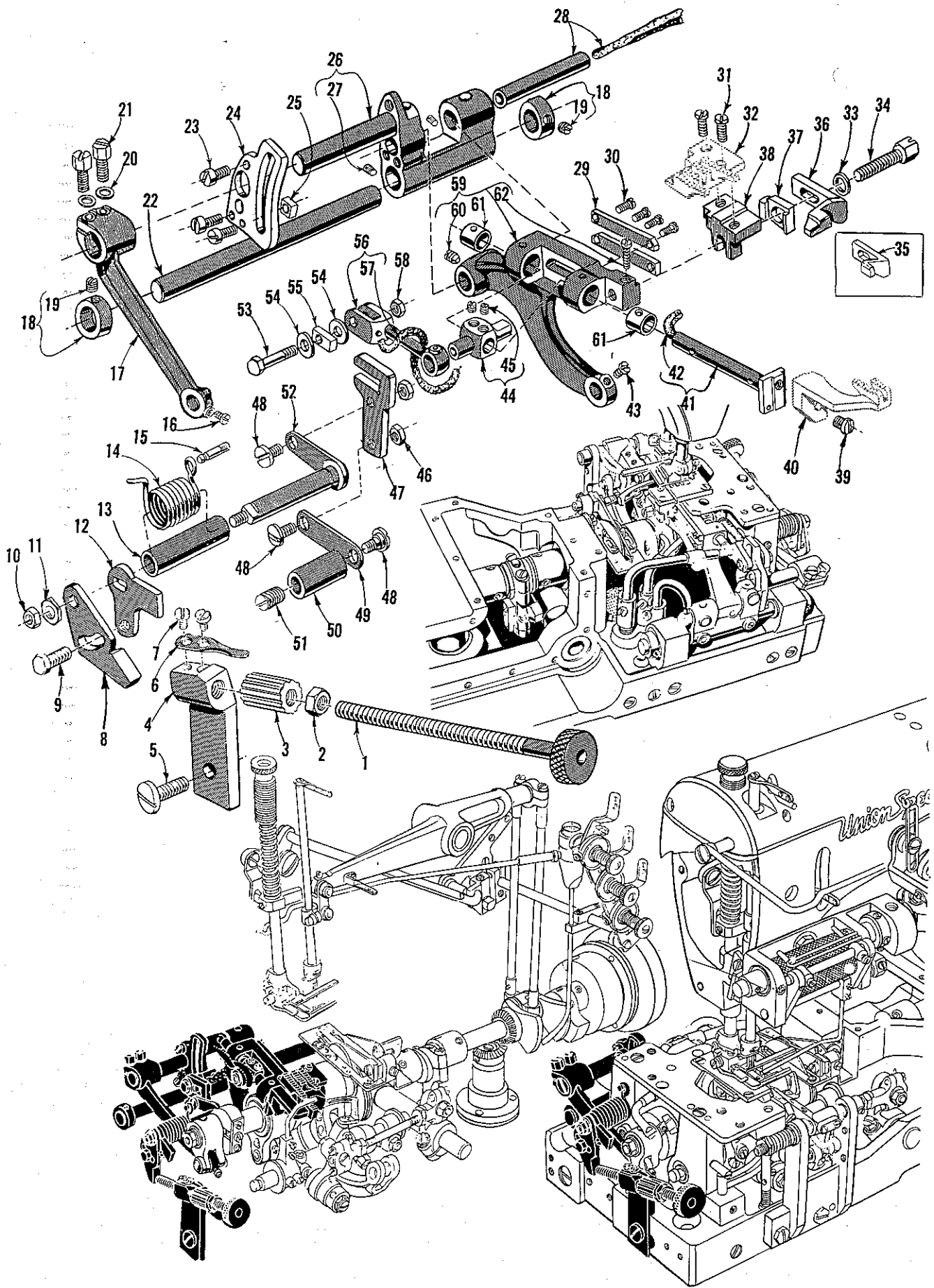

FOR STYLES 52700 BT AND BU ONLY

DIFFERENTIAL FEED MECHANISM PARTS

<u>Ref. No.</u>	<u>Part No.</u>	<u>Description</u>	<u>Amt. Req.</u>
1	51235 P	Thumbscrew, for adjusting differential feed	1
2	258	Nut	1
3	51235 R	Ratchet Nut	1
4	51235 Q	Bracket	1
5	9663	Screw	1
6	51235 S	Ratchet Spring	1
7	28	Screw	2
8	51235 N	Differential Feed Adjusting Lever	1
9	303	Screw	1
10	12934 A	Nut	1
11	14077	Nut	1
12	51235 M	Segment Stop	1
13	51435 B	Control Lever Bushing	1
14	52835 K	Control Lever Spring	1
15	61267 G	Pin	1
16	77	Screw	1
17	52836 C	Feed Rocker Arm	1
18	482	Collar	2
19	98	Screw	1
20	51235 G	Washer	2
21	22519 C	Screw	2
22	8	Feed Rocker Shaft	1
23	22516	Screw	3
24	52836 H	Feed Rocker Segment Plate	1
25	57836 F-40	Sliding Block, marked 'N', .2540 inch wide	1
-	57836 F-45	Sliding Block, marked 'P', .2545 inch wide	1
-	57836 F-50	Sliding Block, marked 'R', .2550 inch wide	1
26	52836	Feed Rocker	1
27	22894 P	Screw	2
28	51134 C	Feed Bar Shaft	1
29	39237 D	Differential Feed Bar Guide Plate	2
30	22593	Screw	4
31	22 KH	Screw	2
32		Main Feed Dog (See Pages 33, 35)	1
33	51235 G	Washer	1
34	22519 J	Screw	1
35	52825 B	Needle Guard, for Style 52700 BU	1
-	52825 F	Needle Guard, for Style 52700 BT	1
36	52825 A	Needle Guard	1
37	52925 D	Needle Guard Holder	1
38	52953	Main Feed Dog Holder	1
39	90	Screw	1
40		Differential Feed Dog (See Pages 33, 35)	1
41	52834 H	Differential Feed Bar	1
42	CL21	Oil Wick	1
43	77	Screw	1
44	39237	Differential Feed Bar Guide	1
45	22565 C	Screw	2
46	12934 A	Nut	2
47	52835 Q	Differential Feed Fork	1
48	22758 B	Screw	3
49	52835 G	Differential Feed Control Lever Link	1
50	52835 U	Pivot Stud Insert	1
51	719	Screw	1
52	51435	Differential Feed Control Lever, rear	1
53	22868 A	Screw	1
54	51225 W	Washer	2
55	52835 S	Differential Feed Fork Block	1
56	52835 V	Differential Feed Bar Driving Link	1
57	CL21	Oil Wick	1
58	907	Nut	1
59	52834	Main Feed Bar	1
60	22560 B	Screw	1
61	39237 G	Bushing	2
62	22747	Feed Dog Height Adjusting Screw	1

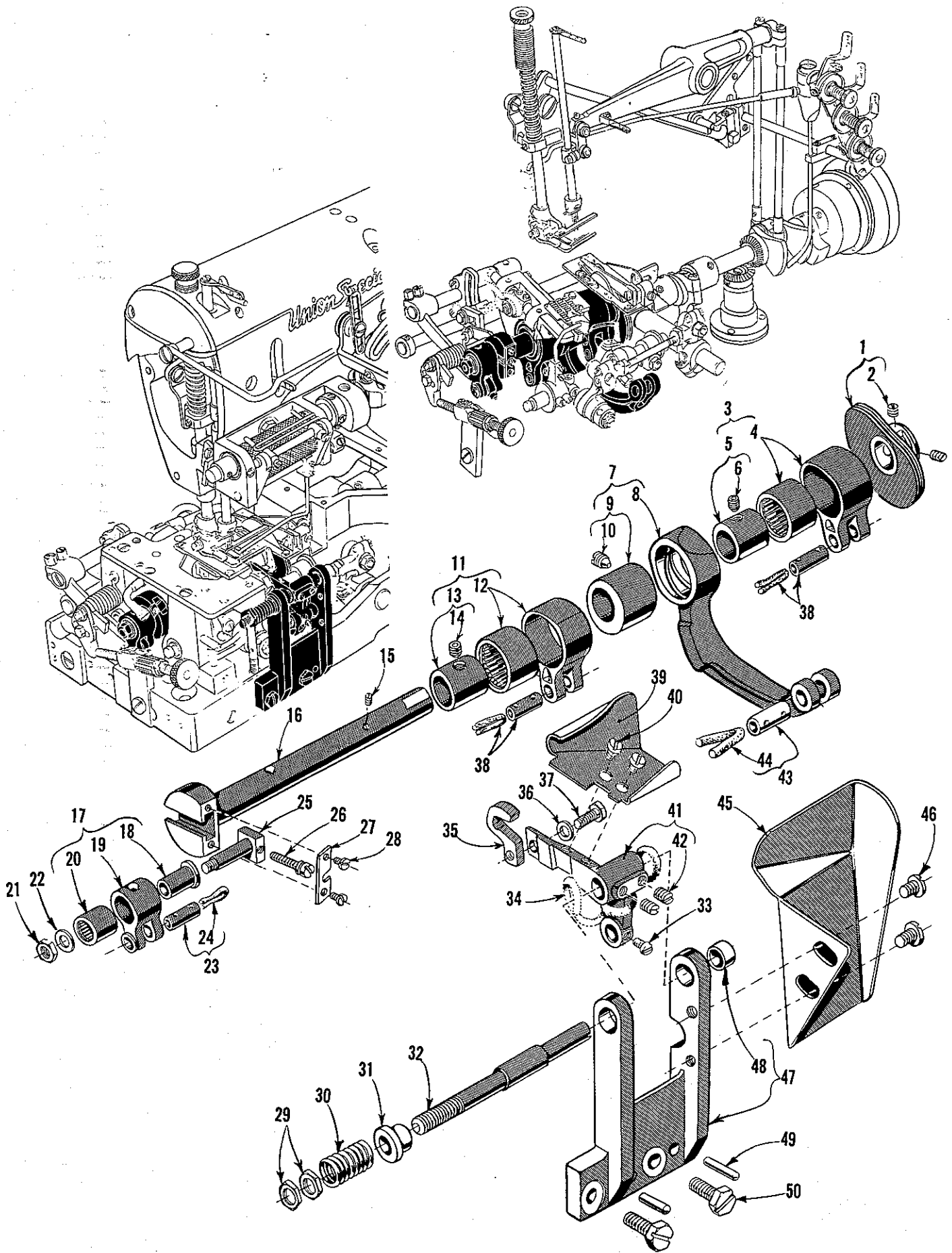

MAIN SHAFT AND KNIFE DRIVING PARTS

<u>Ref. No.</u>	<u>Part No.</u>	<u>Description</u>	<u>Amt. Req.</u>
1	52923 D	Take-up -----	1
2	22580 D	Screw -----	2
* 3	29476 JN	Looper Avoid Eccentric Assembly, for Styles 52700 BT, BU without improved trimming mechanism -----	1
*	29476 DV	Looper Avoid Eccentric Assembly, for Styles 52700 BL, BM, BN, BP, BR, BS, BV without improved trimming mechanism -----	1
	29476 DX	Looper Avoid Eccentric Assembly, for Style 52700 BK-----	1
4	51145 A	Eccentric Bearing -----	1
5	51406	Eccentric, .062 inch throw, for 29476 DV, JN-----	1
	51306	Eccentric, .072 inch throw, for 29476 DX-----	1
6	22894 T	Screw, for 29476 JN-----	1
	22894 D	Screw, for 29476 DV, DX -----	1
* 7	29132 AC	Knife Drive Eccentric Assembly, for Styles 52700 BR, BS, BT, BU without improved trimming mechanism -----	1
8	52774	Connecting Rod-----	1
9	52775	Eccentric, .160 inch throw -----	1
10	22894 C	Screw -----	1
11	29476 DV	Feed Lift Eccentric Assembly -----	1
12	51145 A	Eccentric Bearing -----	1
13	51406	Eccentric, .062 inch throw -----	1
14	22894 D	Screw -----	1
15	22801	Screw -----	1
*16	52722	Main Shaft, for Styles 52700 BR, BS, BV without improved trimming mechanism -----	1
-	52722 E	Main Shaft, for Styles 52700 BR, BS with improved trimming mechanism -----	1
* -	52722 B	Main Shaft, for Styles 52700 BT, BU without improved trimming mechanism -----	1
-	52722 D	Main Shaft, for Styles 52700 BT, BU with improved trimming mechanism -----	1
	52922 C	Main Shaft, for Styles 52700 BK, BL, BM, EN, BP -----	1
17	51236 E	Feed Crank Link Assembly -----	1
18	51236 F	Feed Crank Link Ferrule -----	1
19	51236 D	Feed Crank Link -----	1
20	660-169	Needle Bearing -----	1
21	269	Nut, left thread -----	1
22	20	Washer -----	1
23	51054	Feed Crank Link Pin -----	1
24	666-149	Oil Wick -----	1
25	51236 G	Feed Crank Stud -----	1
26	22795	Screw -----	1
27	51236 B	Feed Crank Stud Cap -----	1
28	22768	Screw -----	2
29	12987 A	Nut, for Styles 52700 BR, BS, BT, BU-----	2
30	52773 E	Knife Tension Spring, for Styles 52700 BR, BS, BT, BU-----	1
31	52773 C	Knife Rocker Shaft Bushing, for Styles 52700 BR, BS, BT, BU -----	1
*32	52773 D	Knife Rocker Stud, for Styles 52700 BR, BS, BT, BV without improved trimming mechanism -----	1
33	77	Screw -----	1
34	CL21	Oil Wick -----	1
*35	52770 L	Upper Knife, for Styles 52700 BR, BS, BT, BU without improved trimming mechanism -----	1
36	80265	Washer -----	1
*37	22588 A	Screw, for Styles 52700 BR, BS, BT, BU without improved trimming mechanism -----	1
38	51236 A	Link Pin -----	2
*39	52779	Chip Guard, upper, for Styles 52700 BR, BS, BT, BU without improved trimming mechanism -----	1
40	28	Screw -----	2
*41	52773	Knife Driving Lever, for Styles 52700 BR, BS, BT, BU without improved trimming mechanism -----	1
42	22560 B	Screw -----	2
*43	51054	Link Pin, for Styles 52700 BR, BS, BT, BU without improved trimming mechanism -----	1
44	666-149	Oil Wick -----	1
*45	52779 A	Chip Guard, lower, for Styles 52700 BR, BS, BT, BU without improved trimming mechanism -----	1
46	22829	Screw -----	2
*47	52773 A	Knife Bracket, for Styles 52700 BR, BS, BT, BU without improved trimming mechanism -----	1
48	52773 B	Bushing -----	1
49	667 C-10	Dowel Pin -----	2
50	22852 A	Screw -----	2

* See Page 43 for comparable repair parts applicable to Styles 52700 BR, BS, BT, BU with improved trimming mechanism.

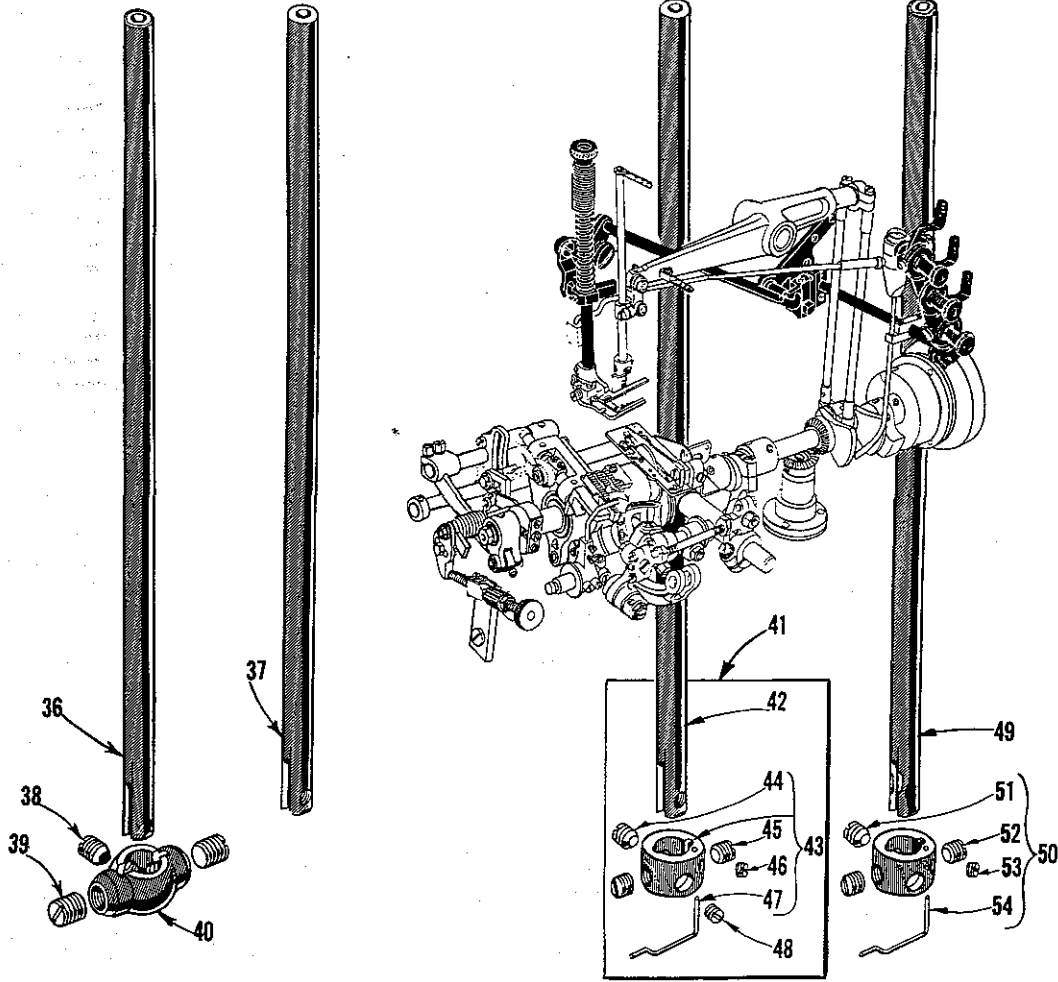
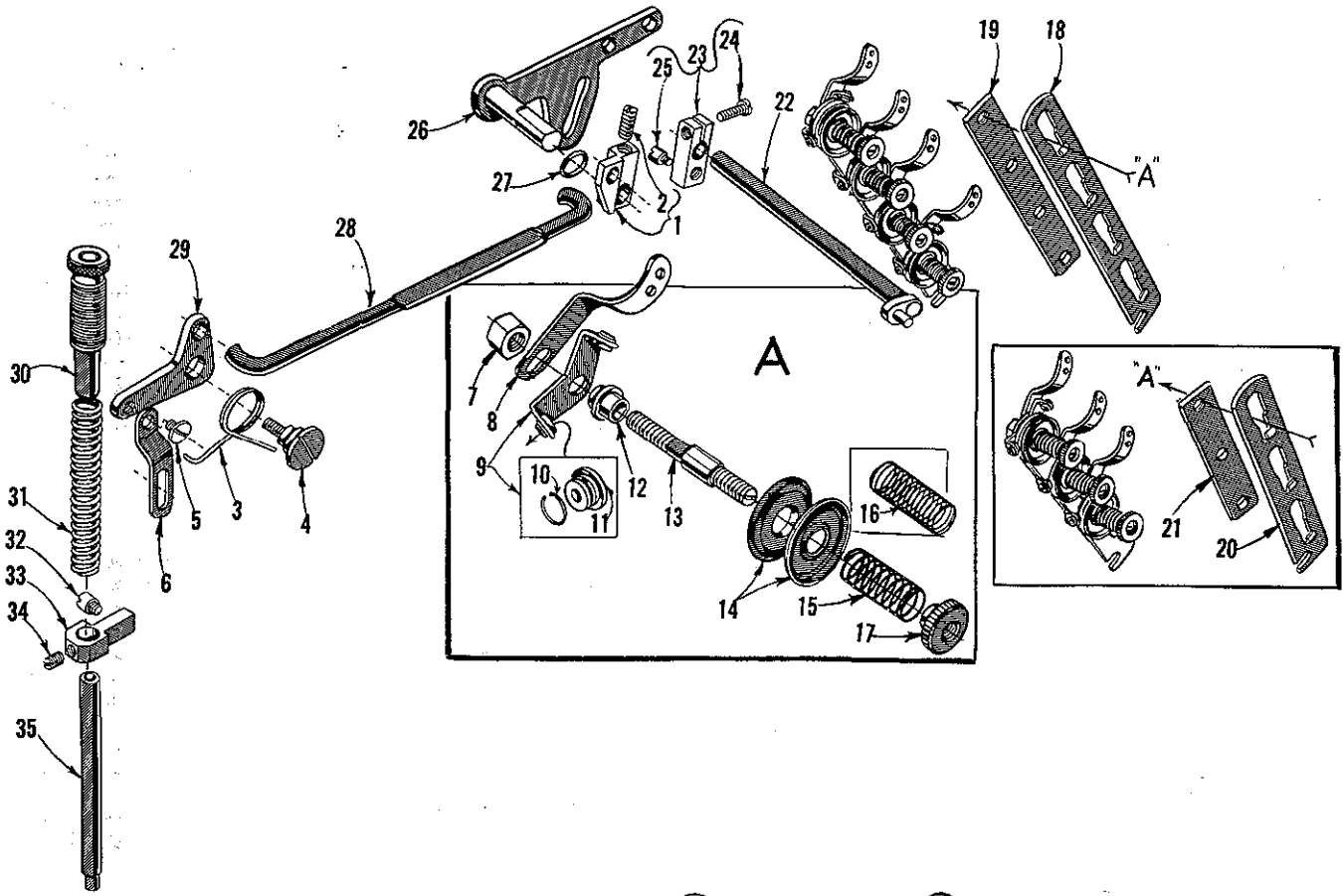

NEEDLE BARS, NEEDLE HOLDERS, THREAD TENSION, AND LIFTER LEVER PARTS

<u>Ref. No.</u>	<u>Part No.</u>	<u>Description</u>	<u>Amt. Req.</u>
1	53783 N	Presser Foot Lifter Lever, internal-----	1
2	22537	Screw-----	1
3	52883 S	Presser Foot Lifter Lever Bell Crank Spring-----	1
4	22557 B	Screw-----	1
5	22758 C	Screw-----	1
6	53783 A	Lifter Lever Link-----	1
7	43266	Nut, for Styles 52700 BK, BL, BN, BP, BR, BT, BV-----	1
	43266	Nut, for Styles 52700 BM, BS, BU-----	2
8	51491 C	Thread Lead-in Guide, for Styles 52700 BK, BL, BN, BP, BR, BT, BV-----	3
	51491 C	Thread Lead-in Guide, for Styles 52700 BM, BS, BU-----	4
9	51292 D	Tension Thread Eyelet, for Styles 52700 BK, BL, BN, BP, BR, BT, BV-----	3
	51292 D	Tension Thread Eyelet, for Styles 52700 BM, BS, BU-----	4
10	668-28	Eyelet Locking Ring-----	1
11	668-25	Eyelet Insert-----	1
12	51292 A	Tension Post Ferrule, for Styles 52700 BK, BL, BN, BP, BR, BT, BV-----	3
	51292 A	Tension Post Ferrule, for Styles 52700 BM, BS, BU-----	4
13	51292 G	Tension Post, for Styles 52700 BK, BL, BN, BP, BR, BT, BV-----	3
	51292 G	Tension Post, for Styles 52700 BM, BS, BU-----	4
14	109	Tension Disc, for Styles 52700 BK, BL, BN, BP, BR, BT, BV-----	6
	109	Tension Disc, for Styles 52700 BM, BS, BU-----	8
15	51292 F-5	Tension Spring, needle, for Styles 52700 BL, BN, BP, BR, BT, BV-----	2
	51292 F-8	Tension Spring, needle, for Styles 52700 BM, BS, BU-----	3
	51292 F-8	Tension Spring, needle, for Style 52700 BK-----	2
16	51292 F-1	Tension Spring, looper, for all Styles except 52700 BK, BM, BS, BU-----	1
	51292 F-2	Tension Spring, looper, for Styles 52700 BK, BM, BS, BU-----	1
17	51292 C	Tension Nut, for Styles 52700 BK, BL, BN, BP, BR, BT, BV-----	3
	51292 C	Tension Nut, for Styles 52700 BM, BS, BU-----	4
18	21657-4	Tension Disc Separator, for Styles 52700 BM, BS, BU-----	1
19	56382 X	Tension Post Support, for Styles 52700 BM, BS, BU-----	1
20	21657-3	Tension Disc Separator, for Styles 52700 BK, BL, BN, BP, BR, BT, BV-----	1
21	52892	Tension Post Support, for Styles 52700 BK, BL, BN, BP, BR, BT, BV-----	1
22	21657 W	Tension Release Lever Shaft-----	1
23	21657 Y	Tension Release Lever Connection-----	1
24	22596	Screw-----	1
25	402	Screw-----	1
26	51283 H	Presser Foot Lifter Lever-----	1
27	660-207	Oil Seal Ring-----	1
28	53783 M	Presser Foot Lifter Lever Connecting Rod-----	1
29	53783 L	Presser Foot Lifter Lever Crank-----	1
30	56356	Presser Spring Regulator-----	1
31	51256 C	Presser Bar Spring-----	1
32	402	Screw-----	1
33	51257 M	Presser Bar Connection and Guide-----	1
34	531	Screw-----	1
35	51257 K	Presser Bar-----	1
36	52717 E-12	Needle Bar, for 2 needle, No. 12 gauge, Styles 52700 BK, BL, BN, BR, BV-----	1
37	52817-16	Needle Bar, for 2 needle, No. 16 gauge, Styles 52700 BK, BL, BN-----	1
38	89	Screw-----	1
39	98	Screw, for Styles 52700 BL, BN-----	2
	95	Screw, for Style 52700 BK-----	2
40	52718-12	Needle Holder, for 2 needle, Nos. 12 and 16 gauge, Styles 52700 BK, BL, BN-----	1
41	29264 S-16	Needle Bar Assembly, for 3 needle, No. 16 gauge, Styles 52700 BM, BS, BU-----	1
42	52817-16	Needle Bar-----	1
43	52818-8	Needle Holder-----	1
44	89	Screw-----	1
45	88 B	Screw-----	2
46	28 B	Screw-----	1
47	52842 G	Thread Guide Wire-----	1
48	28 C	Screw-----	1
49	52817 E-8	Needle Bar, for 2 needle, No. 8 gauge, Style 52700 BN, BP, BR, BT-----	1
50	52818-8	Needle Holder, for 2 needle, No. 8 gauge, Styles 52700 BN, BP, BR, BT and 2 needle, No. 12 gauge, Styles 52700 BR, BV-----	1
51	89	Screw-----	1
52	88 B	Screw-----	2
53	28 B	Screw-----	1
54	52842 G	Thread Guide Wire-----	1

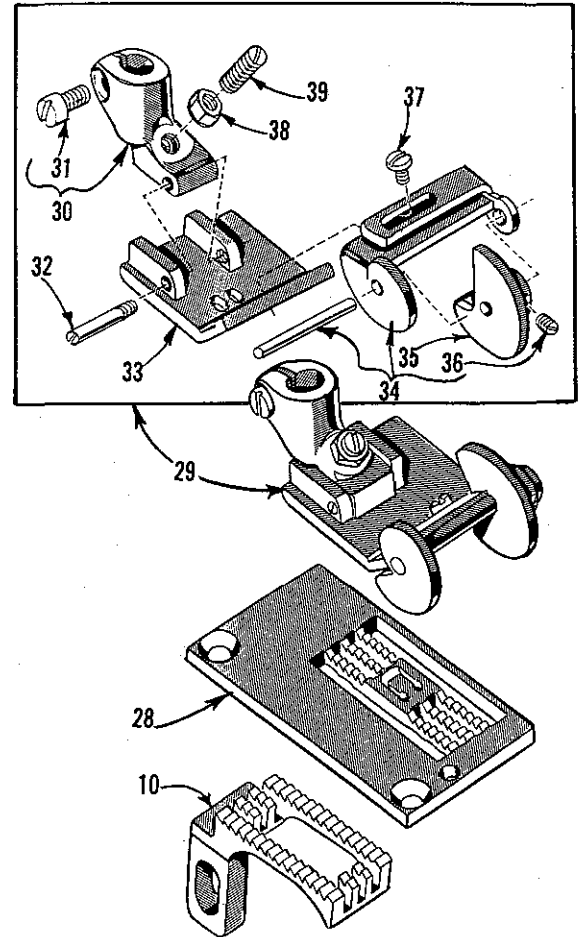
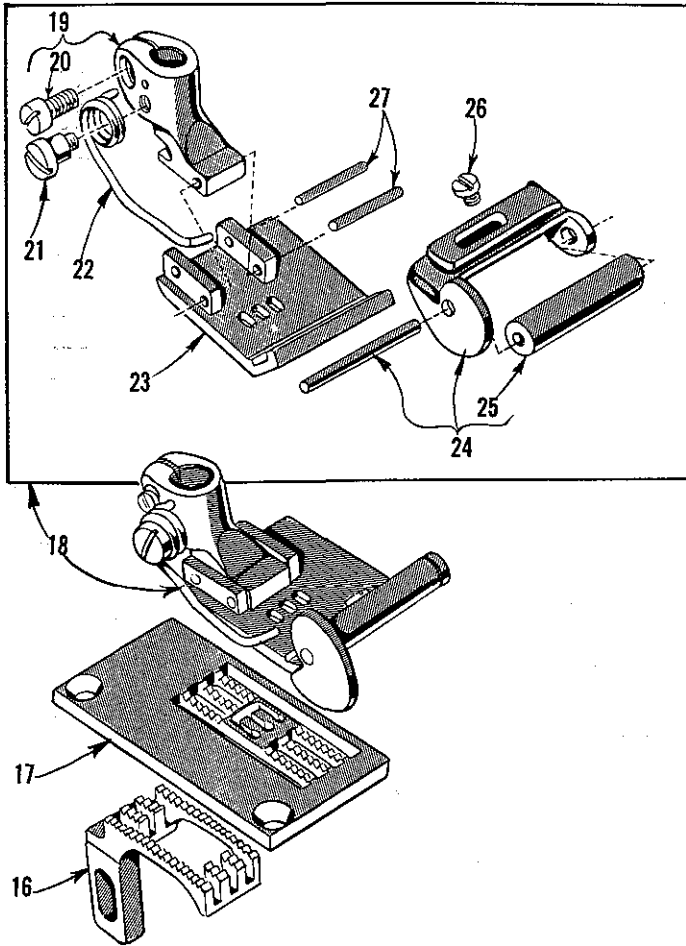
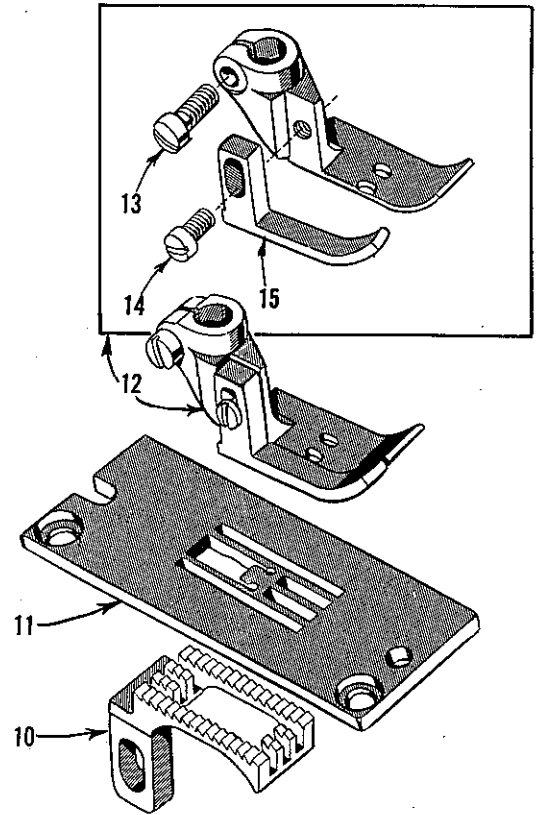
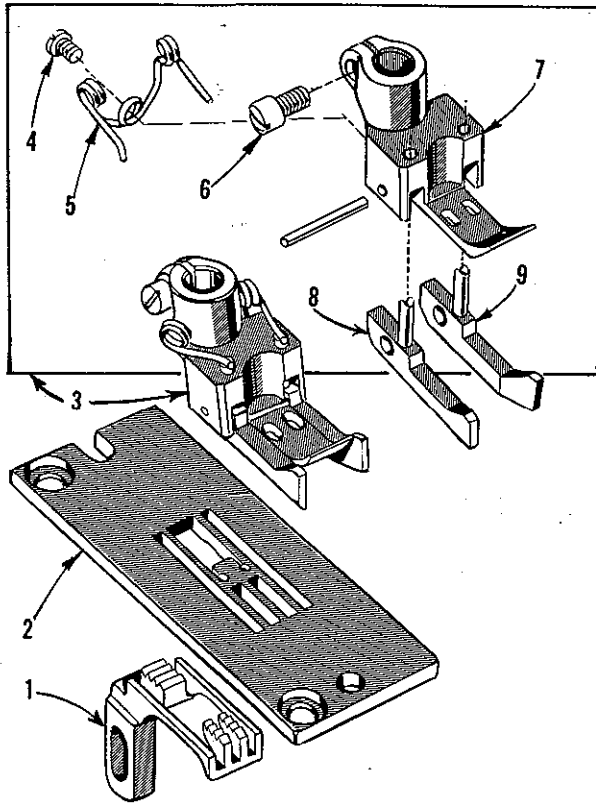

FEED DOGS, THROAT PLATES AND PRESSER FEET

<u>Ref. No.</u>	<u>Part No.</u>	<u>Description</u>	<u>Amt. Req.</u>
1	6905 H-12	Feed Dog, for No. 12 gauge, Style 52700 BK-----	1
	6905 H-16	Feed Dog, for No. 16 gauge, Style 52700 BK-----	1
2	52724 A-12	Throat Plate, for No. 12 gauge, Style 52700 BK-----	1
	52724 A-16	Throat Plate, for No. 16 gauge, Style 52700 BK-----	1
3	6920 A-12	Presser Foot, for No. 12 gauge, Style 52700 BK-----	1
	6920 A-16	Presser Foot, for No. 16 gauge, Style 52700 BK-----	1
4	605	Screw-----	1
5	11940	Spring, for yielding section-----	1
6	91	Screw-----	1
7	6930 A-12	Bottom, for No. 6920 A-12-----	1
	6930 A-16	Bottom, for No. 6920 A-16-----	1
8	6942 A	Yielding Section, left-----	1
9	6941 A	Yielding Section, right-----	1
10	7205 A	Feed Dog, for No. 8 gauge, Styles 52700 BN, BP, No. 12 gauge, Styles 52700 BL, BN-----	1
	22 JE	Feed Dog, for No. 16 gauge, Style 52700 BL-----	1
	22 JW	Feed Dog, for No. 16 gauge, Style 52700 BN-----	1
11	52724 B-12	Throat Plate, for No. 12 gauge, Style 52700 BL-----	1
	52724 B-16	Throat Plate, for No. 16 gauge, Style 52700 BL-----	1
12	52720 B-12	Presser Foot, for No. 12 gauge, Style 52700 BL-----	1
	52720 B-16	Presser Foot, for No. 16 gauge, Style 52700 BL-----	1
13	91	Screw-----	1
14	22593	Screw-----	1
15	52730 B	Adjustable Section, for Nos. 52720 B-12, -16----	1
16	52705 G	Feed Dog, for No. 16 gauge, Style 52700 BM-----	1
17	52724 G-16	Throat Plate, for No. 16 gauge, Style 52700 BM-----	1
18	52720 G-16	Presser Foot, for No. 16 gauge, Style 52700 BM-----	1
19	52730	Shank-----	1
20	91	Screw-----	1
21	57 WD	Screw-----	1
22	15480 C	Spring-----	1
23	52730 G-16	Presser Foot Bottom-----	1
24	52730 A	Adjustable Edge Guide-----	1
25	52730 C	Roller-----	1
26	604	Screw-----	1
27	52730 X-531	Hinge Pin-----	2
28	52724 H-8	Throat Plate, for No. 8 gauge, Styles 52700 BN, BP--	1
	52724 H-12	Throat Plate, for No. 12 gauge, Style 52700 BN-----	1
*	112 DW	Throat Plate, for No. 16 gauge, Style 52700 BN-----	1
29	52720 J-8	Presser Foot, for No. 8 gauge, Styles 52700 BN, BP--	1
	52720 J-12	Presser Foot, for No. 12 gauge, Style 52700 BN-----	1
*	K51893	Presser Foot, for No. 16 gauge, Style 52700 BN-----	1
30	51430 D	Presser Foot Shank, for Nos. 52720 J-8, -12----	1
31	91	Screw-----	1
32	22799 B	Hinge Screw, for Nos. 52720 J-8, -12-----	1
33	52730 U-8	Presser Foot Bottom, for No. 52720 J-8-----	1
	52730 U-12	Presser Foot Bottom, for No. 52720 J-12-----	1
34	52730 W	Adjustable Edge Guide, for Nos. 52720 J-8, -12---	1
	52730 C	Edge Guide Roller, for No. K51893-----	1
35	52730 V	Auxiliary Edge Guide-----	1
36	1096	Screw-----	1
37	604	Screw, for Nos. 52720 J-8, -12-----	1
38	51430 F	Nut, for Nos. 52720 J-8, -12-----	1
39	22840 A	Screw, for Nos. 52720 J-8, -12-----	1

* Not Illustrated

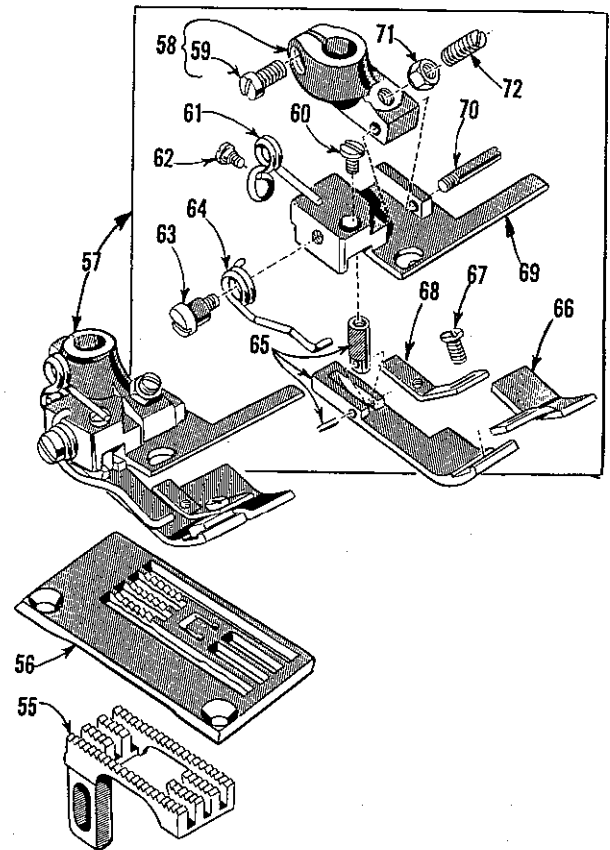
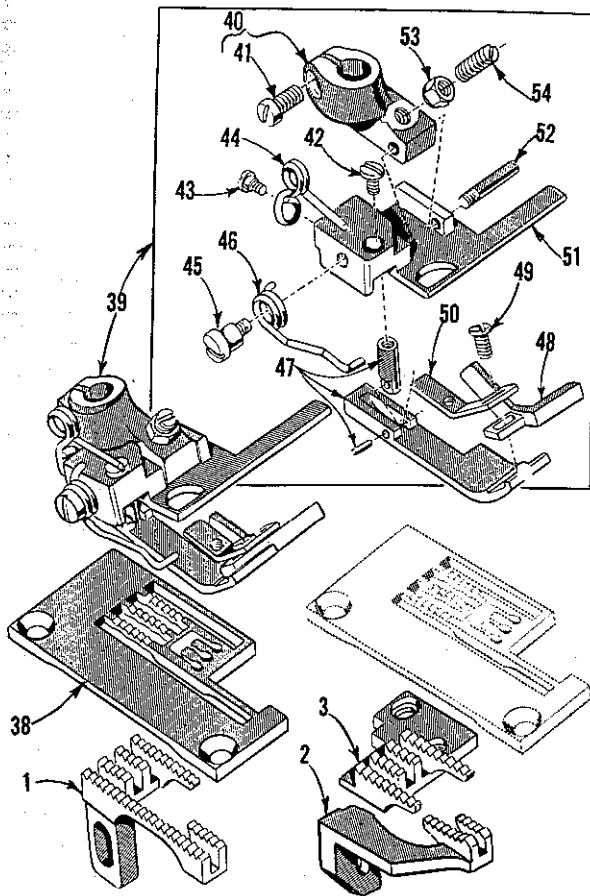
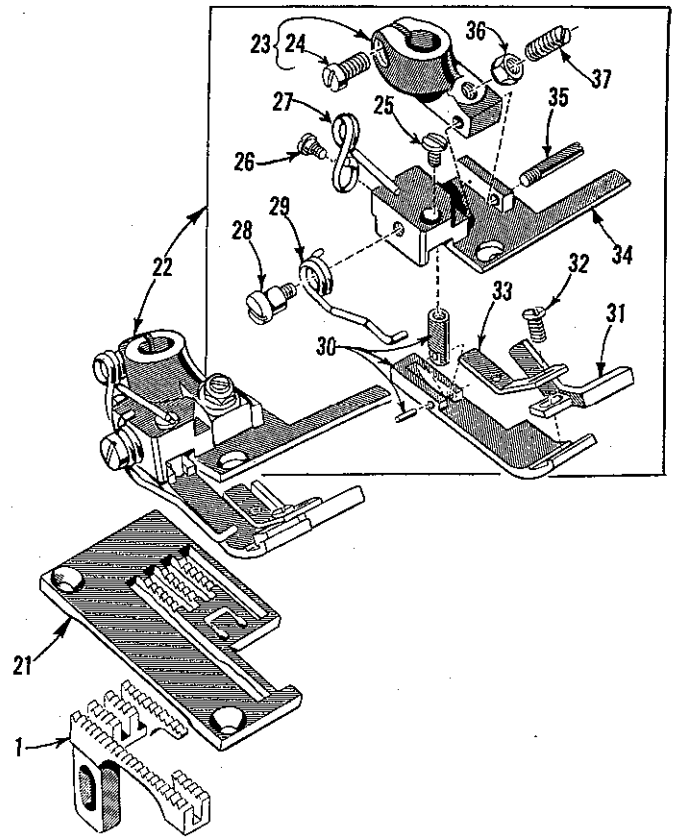
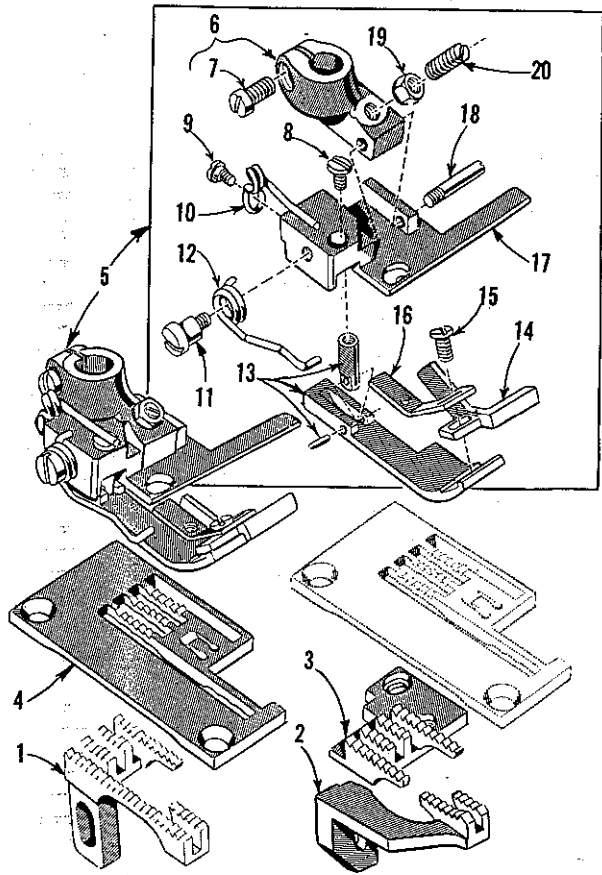

FEED DOGS, THROAT PLATES AND PRESSER FEET

<u>Ref. No.</u>	<u>Part No.</u>	<u>Description</u>	<u>Amt. Req.</u>
* 1	52705 C-16	Feed Dog, for Nos. 8, 12 gauges Style 52700 BR and No. 16 gauge Style 52700 BS	1
* 2	52726	Differential Feed Dog, for No. 8 gauge Style 52700 BT and No. 16 gauge Style 52700 BU	1
* 3	52705 E	Main Feed Dog, for No. 8 gauge Style 52700 BT and No. 16 gauge Style 52700 BU	1
* 4	52724 D-8	Throat Plate, for No. 8 gauge Styles 52700 BR, BT	1
* 5	52720 D-8	Presser Foot, for No. 8 gauge Styles 52700 BR, BT	1
6	52730 T	Presser Foot Shank	1
7	91	Screw	1
8	73 A	Screw	1
9	605	Screw	1
10	52730 AB	Torsion Spring	1
11	57 WD	Screw	1
12	52730 Y	Spring	1
13	52730 P	Presser Foot Yielding Section	1
14	52730 R	Presser Foot Chip Guard	1
15	605 A	Screw	1
16	52730 AE	Presser Foot Tape Guide	1
17	52730 D-8	Presser Foot Bottom	1
18	22799 B	Hinge Pin	1
19	51430 F	Nut	1
20	22840 A	Screw	1
*21	52724 D-12	Throat Plate, for No. 12 gauge Style 52700 BR	1
*22	52720 K-12	Presser Foot, for No. 12 gauge Style 52700 BR	1
23	52730 T	Presser Foot Shank	1
24	91	Screw	1
25	73 A	Screw	1
26	605	Screw	1
27	52730 AB	Torsion Spring	1
28	57 WD	Screw	1
29	51230 T	Spring	1
30	52730 P	Presser Foot Yielding Section	1
31	52730 R	Presser Foot Chip Guard	1
32	605 A	Screw	1
33	52730 AE	Presser Foot Tape Guide	1
34	52730 Z	Presser Foot Bottom	1
35	22799 B	Hinge Pin	1
36	51430 F	Nut	1
37	22840 A	Screw	1
*38	52724 C-16	Throat Plate, for No. 16 gauge Styles 52700 BS, BU (for 12 to 16 S. P. I.)	1
* -	52728 C-16	Throat Plate, for No. 16 gauge Styles 52700 BS, BU (for 9 to 11 S. P. I.)	1
*39	52720 C-16	Presser Foot, for No. 16 gauge Styles 52700 BS, BU	1
40	52730 T	Presser Foot Shank	1
41	91	Screw	1
42	73 A	Screw	1
43	605	Screw	1
44	52730 AB	Torsion Spring	1
45	57 WD	Screw	1
46	52730 Y	Spring	1
47	52730 P	Presser Foot Yielding Section	1
48	52730 R	Presser Foot Chip Guard	1
49	605 A	Screw	1
50	52730 AE	Presser Foot Tape Guide	1
51	52730 E-16	Presser Foot Bottom	1
52	22799 B	Hinge Pin	1
53	51430 F	Nut	1
54	22840 A	Screw	1
55	52705 J-12	Feed Dog, for No. 12 gauge, Style 52700 BV	1
56	52724 J-12	Throat Plate, for No. 12 gauge Style 52700 BV	1
57	52720 L-12	Presser Foot, for No. 12 gauge Style 52700 BV	1
58	52730 T	Presser Foot Shank	1
59	91	Screw	1
60	73 A	Screw	1
61	52730 AB	Spring	1
62	605	Screw	1
63	57 WD	Screw	1
64	51230 T	Spring	1
65	52730 P	Presser Foot Yielding Section	1
66	52730 AA	Auxiliary Toe	1
67	605 A	Screw	1
68	52730 AE	Presser Foot Tape Guide	1
69	52730 Z	Presser Foot Bottom	1
70	22799 B	Hinge Pin	1
71	51430 F	Nut	1
72	22840 A	Screw	1

* Sewing parts are applicable to Machine Styles as indicated, without improved trimming mechanism. Comparable sewing parts applicable to specified Machine Styles with improved trimming mechanism are listed on Pages 39 and 41.

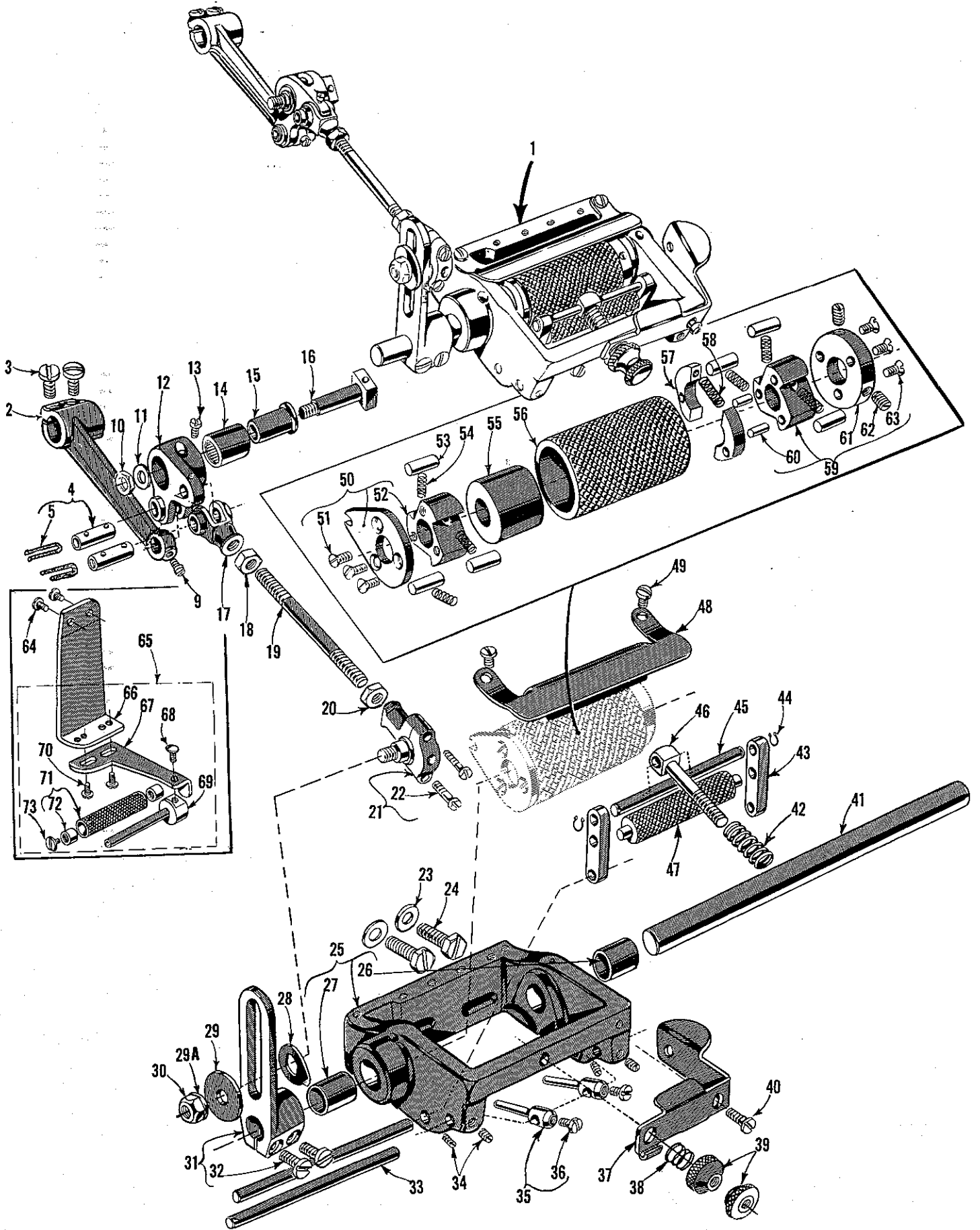

FOR STYLE 52700 BP ONLY

ELASTIC METERING DEVICE

<u>Ref. No.</u>	<u>Part No.</u>	<u>Description</u>	<u>Amt. Req.</u>
1	29486 F	Elastic Metering Device, complete	1
2	51235 A	Feed Rocker Arm	1
3	93	Screw	2
4	51054	Link Pin	2
9	77	Screw	1
10	269	Nut	1
11	20	Washer	1
12	52736	Feed Crank Link	1
13	77	Screw	1
14	660-169	Needle Bearing	1
15	51236 F	Feed Crank Link Ferrule	1
16	51236 G	Feed Crank Stud	1
17	52776 F	Connecting Rod Link	1
18	12538	Nut	1
19	39141	Connecting Rod	1
20	269	Nut	1
21	52776 C	Ball Joint	1
22	97 A	Cap Screw	2
23	21657 E	Washer	2
24	627 A	Screw	2
25	52776	Frame	1
26	80692	Bushing, right	1
27	80662	Bushing, left	1
28	52776 E	Indicator Washer	1
29	39258 C	Washer	1
29A	20	Washer	1
30	18	Nut	1
31	52776 B	Driving Arm	1
32	93	Screw	2
33	52778 B	Pivot Shaft	2
34	22565 C	Screw	4
35	52778 D	Guide	2
36	22562	Screw	2
37	52778 L	Tension Release Lever	1
38	52778 M	Spring	1
39	434	Adjusting Nut	2
40	22594	Screw	1
41	52776 A	Shaft	1
42	52778 J	Spring	1
43	52778 G	Strip Tension Roller End Plate	2
44	660-228	Retaining Ring	2
45	52778 H	Strip Tension Roller End Plate Shaft, upper	1
46	52778 K	Strip Tension Roller Spring Stud	1
47	52778 F	Strip Tension Roller	1
48	52777 K	Feed Roller Guard	1
49	90	Screw	2
50	52777 H	Check Clutch Arm	1
51	22589	Screw	3
52	52777 J	Check Clutch	1
53	52777 C	Clutch Roller	6
54	52777 D	Roller Clutch Spring	6
55	52777 G	Spacing Collar	1
56	52777	Feed Roller	1
57	52777 E	Brake Shoe	2
58	52777 F	Brake Shoe Spring	1
59	52777 A	Driving Clutch	1
60	51280 J	Dowel Pin	2
61	52777 B	Clutch Driving Collar	1
62	531	Screw	2
63	22589	Screw	3
64	22848	Screw	2
65	23307 J	Elastic Guide Roller and Bracket Assembly	1
66	23307 N	Bracket	1
67	23307 M	Guide Roller Shaft Arm	1
68	22848	Screw	1
69	23307 L	Elastic Guide Roller Shaft	1
70	22848	Screw	2
71	23307 K	Elastic Guide Roller	1
72	660-274	Needle Bearing	2
73	22542	Screw	1

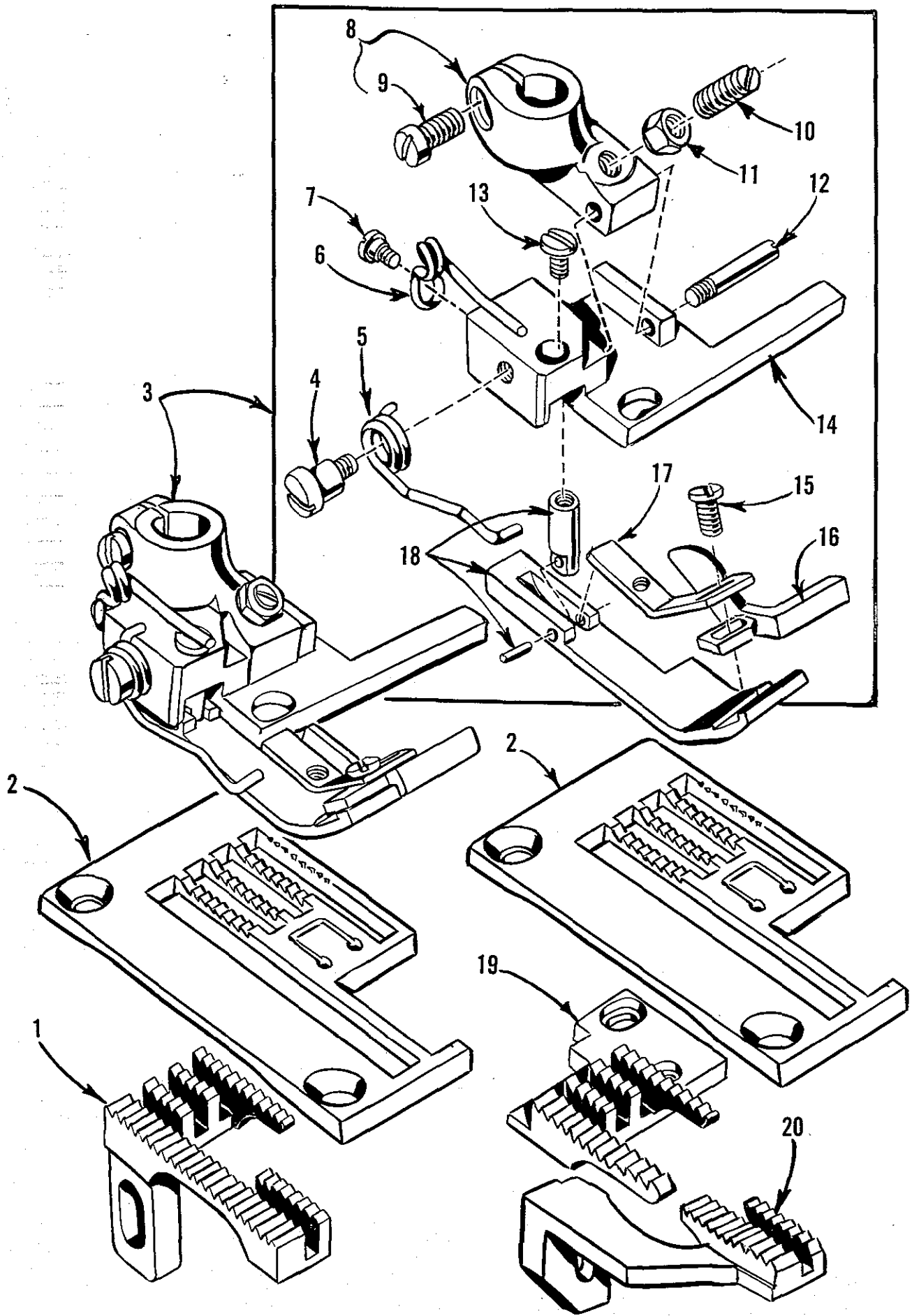

FEED DOGS, THROAT PLATES AND PRESSER FEET
FOR STYLES 52700 BR, BS, BT, BU WITH IMPROVED
TRIMMING MECHANISM ONLY

Ref. No.	Part No.	Description	Amt. Req.
1	52705 N	Feed Dog, for Nos. 8, 12 gauges Style 52700 BR and No. 16 gauge Style 52700 BS -----	1
2	52724 N-8	Throat Plate, for No. 8 gauge Styles 52700 BR, BT (for 12 to 16 S. P. I.) -----	1
	52728 N-8	Throat Plate, for No. 8 gauge Styles 52700 BR, BT (for 9 to 11 S. P. I.) -----	1
3	52720 M-8	Presser Foot, for No. 8 gauge Styles 52700 BR, BT -----	1
4	57 WD	Screw -----	1
5	52730 Y	Spring -----	1
6	52730 AB	Spring -----	1
7	605	Screw -----	1
8	52730 T	Presser Foot Shank -----	1
9	91	Clamp Screw -----	1
10	22840 A	Adjusting Screw -----	1
11	51430 F	Nut -----	1
12	22799 B	Hinge Screw -----	1
13	73 A	Screw -----	1
14	52730 AC-8	Presser Foot Bottom -----	1
15	605 A	Screw -----	1
16	52730 AD	Presser Foot Chip Guard, marked "C" -----	1
17	52730 AE	Presser Foot Tape Guide -----	1
18	52730 AF	Presser Foot Yielding Section -----	1
19	52705 M	Main Feed Dog, marked "CX", for No. 8 gauge Style 52700 BT and No. 16 gauge Style 52700 BU--	1
20	52726 C	Differential Feed Dog, marked "DD", for No. 8 gauge Style 52700 BT and No. 16 gauge Style 52700 BU -----	1

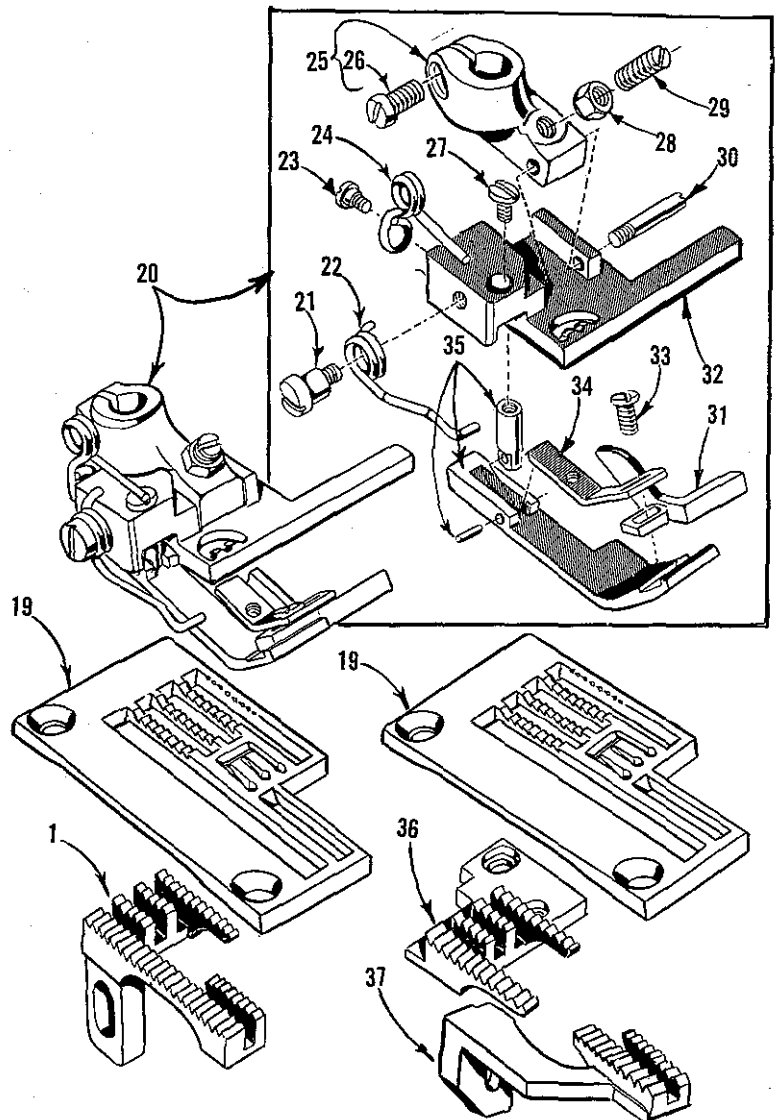
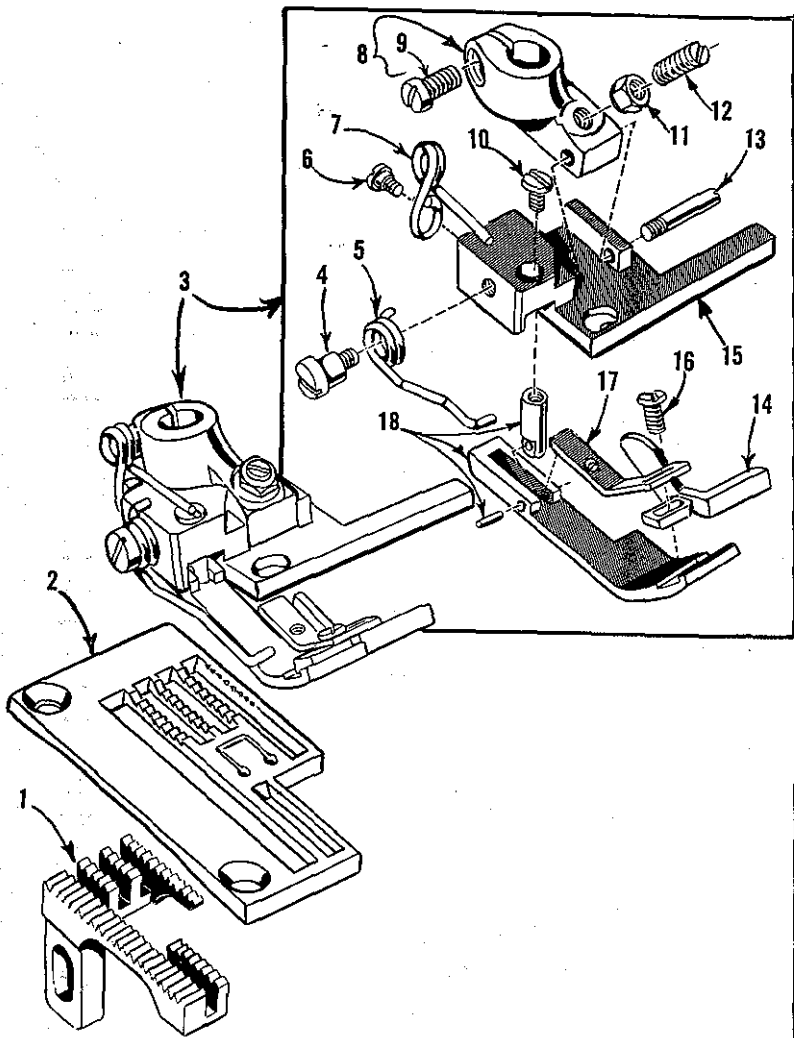

FEED DOGS, THROAT PLATES AND PRESSER FEET
FOR STYLES 52700 BR, BS, BT, BU WITH IMPROVED
TRIMMING MECHANISM ONLY

Ref. No.	Part No.	Description	Amt. Req.
1	52705 N	Feed Dog, for Nos. 8, 12 gauges Style 52700 BR and No. 16 gauge Style 52700 BS-----	1
2	52724 N-12	Throat Plate, for No. 12 gauge Style 52700 BR (for 12 to 16 S. P. I.)-----	1
	52728 N-12	Throat Plate, for No. 12 gauge Style 52700 BR (for 9 to 11 S. P. I.)-----	1
3	52720 M-12	Presser Foot, for No. 12 gauge Style 52700 BR----	1
4	57 WD	Screw-----	1
5	51230 T	Spring-----	1
6	605	Screw-----	1
7	52730 AB	Spring-----	1
8	52730 T	Presser Foot Shank-----	1
9	91	Clamp Screw-----	1
10	73 A	Screw-----	1
11	51430 F	Nut-----	1
12	22840 A	Adjusting Screw-----	1
13	22799 B	Hinge Screw-----	1
14	52730 AD	Presser Foot Chip Guard, marked "C"-----	1
15	52730 AC-12	Presser Foot Bottom-----	1
16	605 A	Screw-----	1
17	52730 AE	Presser Foot Tape Guide-----	1
18	52730 AF	Presser Foot Yielding Section-----	1
19	52724 M-16	Throat Plate, for No. 16 gauge Styles 52700 BS, BU (for 12 to 16 S. P. I.)-----	1
	52728 M-16	Throat Plate, for No. 16 gauge Styles 52700 BS, BU (for 9 to 11 S. P. I.)-----	1
20	52720 M-16	Presser Foot, for No. 16 gauge Styles 52700 BS, BU-----	1
21	57 WD	Screw-----	1
22	52730 Y	Spring-----	1
23	605	Screw-----	1
24	52730 AB	Spring-----	1
25	52730 T	Presser Foot Shank-----	1
26	91	Clamp Screw-----	1
27	73 A	Screw-----	1
28	51430 F	Nut-----	1
29	22840 A	Adjusting Screw-----	1
30	22799 B	Hinge Screw-----	1
31	52730 AD	Presser Foot Chip Guard, marked "C"-----	1
32	52730 AC-16	Presser Foot Bottom-----	1
33	605 A	Screw-----	1
34	52730 AE	Presser Foot Tape Guide-----	1
35	52730 AF	Presser Foot Yielding Section-----	1
36	52705 M	Main Feed Dog, marked "CX", for No. 8 gauge Style 52700 BT and No. 16 gauge Style 52700 BU--	1
37	52726 C	Differential Feed Dog, marked "DD", for No. 8 gauge Style 52700 BT and No. 16 gauge Style 52700 BU-----	1

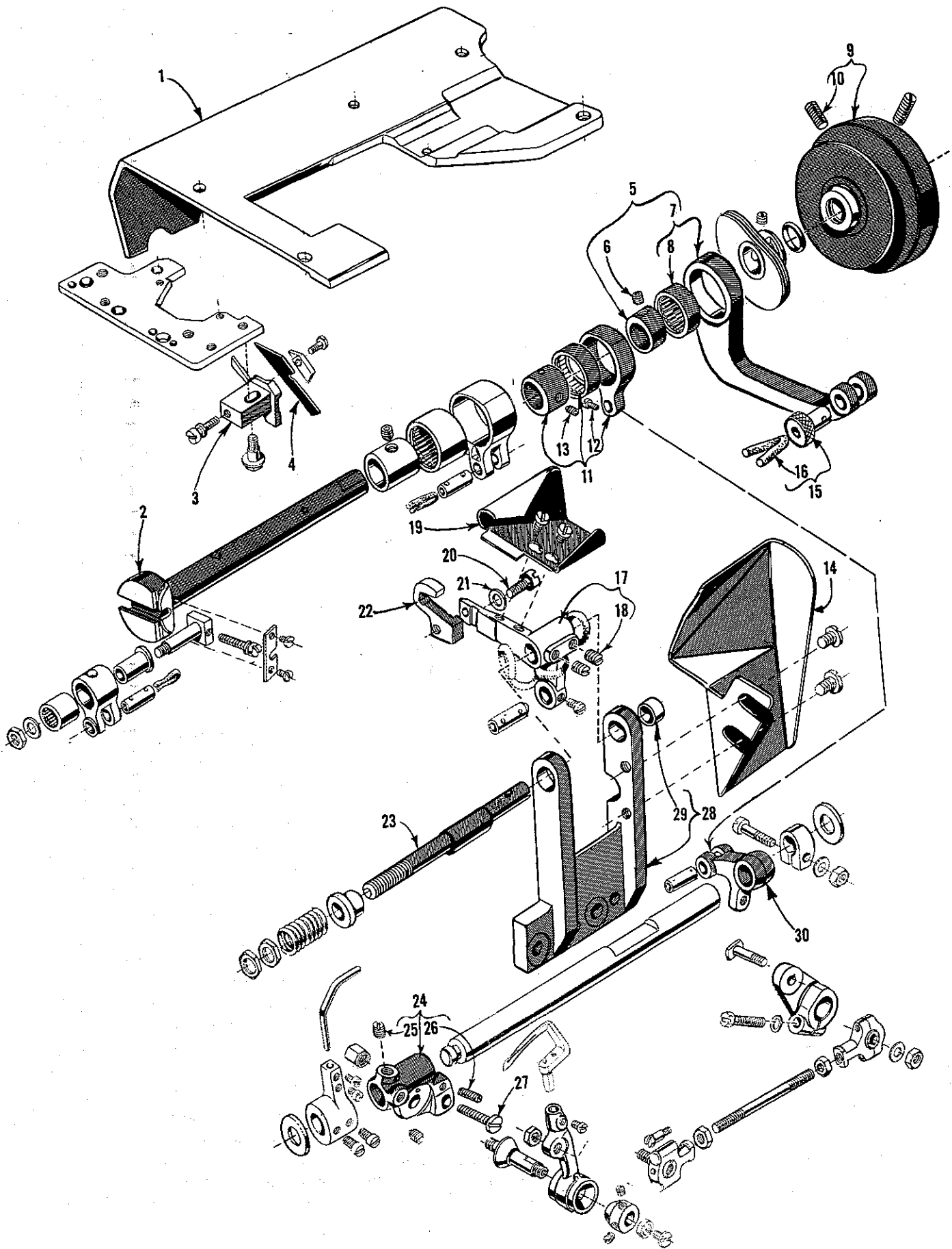

CLOTH PLATE, KNIVES, KNIFE DRIVING PARTS AND
MISCELLANEOUS PARTS FOR STYLES 52700 BR, BS,
BT, BU WITH IMPROVED TRIMMING MECHANISM ONLY

Ref. No.	Part No.	<u>Description</u>	Amt. Req.
1	52701 B	Cloth Plate -----	1
2	52722 D	Main Shaft, for Styles 52700 BT, BU -----	1
-	52722 E	Main Shaft, for Styles 52700 BR, BS -----	1
3	52750 C	Lower Knife Block-----	1
4	52749 A	Lower Knife -----	1
5	29132 AH	Knife Drive Eccentric Assembly, .160 inch throw-----	1
6	22894 T	Set Screw-----	2
7	52774 A	Connecting Rod-----	1
8	660-226	Needle Bearing-----	1
9	52921 B	Pulley-----	1
10	22894 G	Set Screw-----	2
11	29476 NM-062	Looper Avoid Eccentric Link Assembly -----	1
12	77	Set Screw-----	1
13	22894 AA	Set Screw-----	1
14	52779 C	Chip Guard, lower -----	1
15	52773 P	Link Pin, for knife drive eccentric assembly -----	1
16	666-149	Oil Wick -----	1
17	52773 R	Knife Drive Lever -----	1
18	22560 B	Set Screw-----	2
19	52779 B	Chip Guard, upper -----	1
20	22516	Screw, for upper knife -----	1
21	80265	Washer, for upper knife screw-----	1
22	52770 C	Upper Knife, marked "B"-----	1
23	52773 T	Knife Drive Lever Stud-----	1
24	57744 A	Looper Rocker Frame -----	1
25	98	Set Screw-----	1
26	719	Stop Screw-----	1
27	22874	Screw, for looper rocker frame -----	1
28	52773 S	Knife Bracket-----	1
29	52773 B	Bushing, right -----	1
30	56344 B	Looper Rocker Arm -----	1

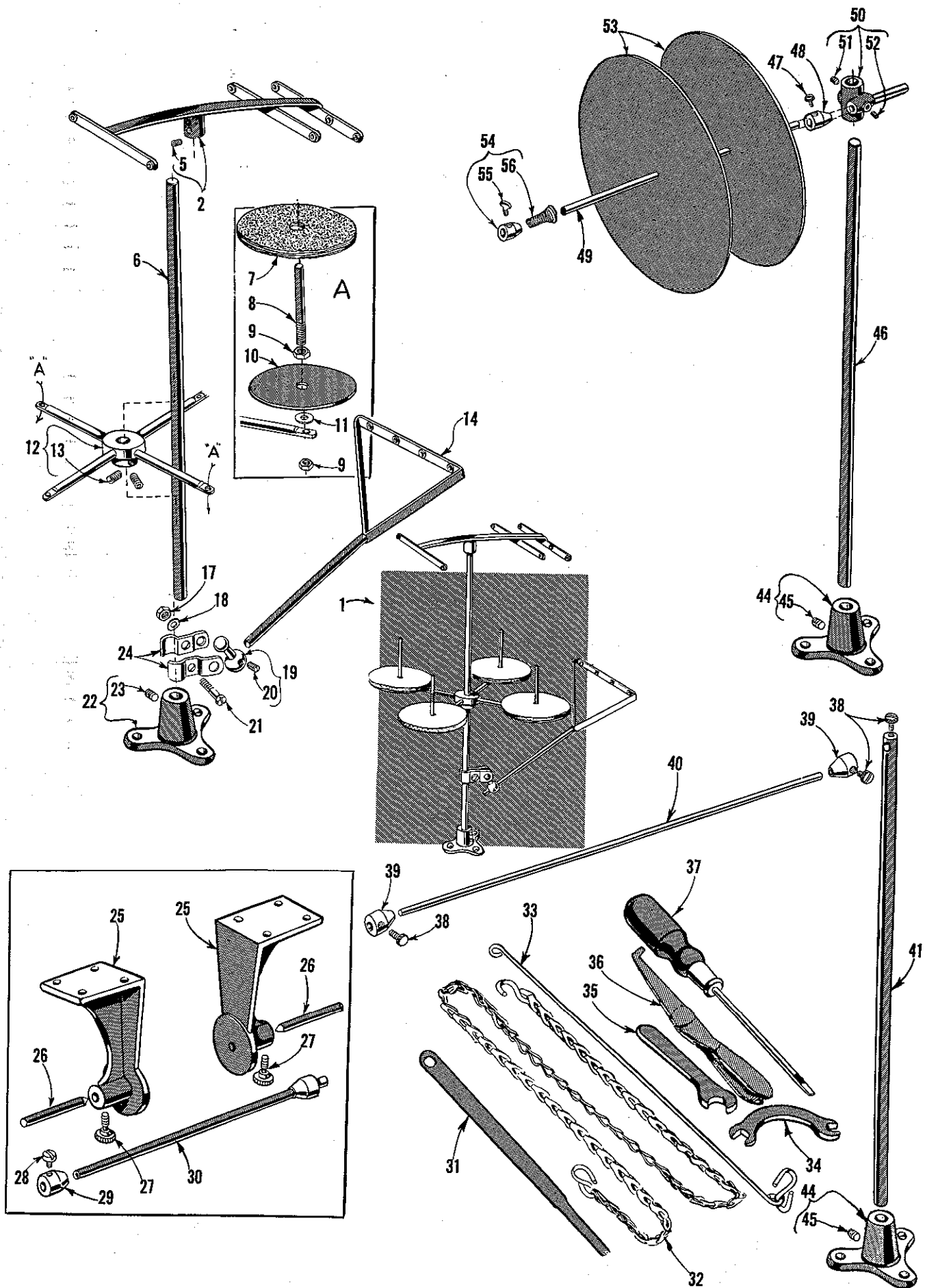

THREAD STAND, TAPE REEL PARTS AND ACCESSORIES

<u>Ref. No.</u>	<u>Part No.</u>	<u>Description</u>	<u>Amt. Req.</u>
1	21101 H-4	Thread Stand, complete-----	1
2	21114 H-4	Eyelet Support -----	1
5	22651 CD-4	Screw-----	1
6	21104 B-24	Thread Stand Rod -----	1
7	21104 V	Pad-----	4
8	21114 W	Spool Pin-----	4
9	258 A	Nut -----	8
10	21114	Spool Seat Disc -----	4
11	652-16	Washer -----	4
12	21114 D-4	Spool Seat Support -----	1
13	22651 CD-5	Screw-----	2
14	21114 S-4	Lead Eyelet -----	1
17	21104 H	Nut -----	1
18	652-16	Washer -----	1
19	21114 T	Lead Eyelet Socket Ball -----	1
20	22651 CD-4	Screw-----	1
21	22810	Screw-----	1
22	21114 A	Thread Stand Base -----	1
23	22651 CD-4	Screw-----	1
24	21114 U	Lead Eyelet Ball Split Socket -----	2
25	201 A	Lower Tape Holder Frame, for Style 52700 BP-----	2
26	751	Spool Support Frame Pin, for Style 52700 BP -----	2
27	201 C	Screw, for Style 52700 BP -----	2
28	188 D	Screw, for Style 52700 BP -----	1
29	753	Axle Cone, for Style 52700 BP-----	1
30	752	Spool Support Rod, for Style 52700 BP-----	1
31	23279 D	Folder Threader, for Styles 52700 BR, BS, BT, BU, BV ---	1
32	421 D-28	Treadle Chain -----	1
33	51493 BC	Lifter Link -----	1
34	21388 W	Wrench, curved double end, 9/32 inch opening, for Styles 52700 BR, BS, BT, BU, BV -----	1
35	21388	Wrench, single end, 3/8 inch opening -----	1
36	660-240	Thread Tweezers -----	1
37	21201	Screw Driver, 9/64 inch round blade, length over-all 7 5/8 inches -----	1
38	188 D	Thumbscrew, for Styles 52700 BR, BS, BT, BU, BV ----	3
39	753	Cone, for Styles 52700 BR, BS, BT, BU, BV -----	2
40	21102 B	Tape Reel Rod, for Styles 52700 BR, BS, BT, BU, BV---	1
41	21216	Tape Reel Support Rod, for Styles 52700 BR, BS, BT, BU, BV-----	1
44	21114 A	Tape Holder Base, for Styles 52700 BM, BN, BR, BS, BT, BU, BV-----	1
45	22651 CD-4	Screw-----	1
46	21104 B-20	Tape Reel Support Rod, for Styles 52700 BM, BN -----	1
47	188 D	Screw, for Styles 52700 BM, BN-----	1
48	753	Axle Cone, for Styles 52700 BM, BN-----	1
49	21102 B	Tape Reel Rod, for Styles 52700 BM, BN -----	1
50	21217 A	Rod Support, for Styles 52700 BM, BN -----	1
51	22651 CD-4	Screw-----	1
52	22650 CB-4	Screw-----	1
53	21178 A	Tape Holder Disc, for Styles 52700 BM, BN -----	2
54	21177 A	Tape Reel Collar, for Styles 52700 BM, BN-----	1
55	22647 K-24	Screw-----	1
56	1349 A-5	Spring -----	1

NUMERICAL INDEX OF PARTS

Part No.	Page No.	Part No.	Page No.	Part No.	Page No.	Part No.	Page No.
8	25, 27	643-127 Blk	15	21210	23	22733 B	13
18	23, 37	652-16	45	21210 A	23	22738	21
20	9, 11, 23, 25, 29, 37	660-136	15	21212	17	22743	21
CL21	21, 27, 29	660-169	25, 29, 37	21216	45	22747	27
22 KH	27	660-202	19, 21	21217 A	45	22758 B	27
22 JE	33	660-207	31	B21375 AH	9	22758 C	31
22 JW	33	660-212	19	21388	45	22760 A	13
25 B	11	660-226	43	21388 W	45	22768	9, 19, 23, 25, 29
25 C	11, 13	660-228	37	21657	31	22798	9
25 S	11	660-240	45	21657 E	9, 37	22799 B	33, 35, 39, 41
25 CC	11	660-274	11, 37	21657 W	31	22799 M	9
27-435 Blk	19	666-65	17	21657 X	17	22801	25, 29
28	27, 29	666-111	17	21657 Y	31	22804	21
28 B	31	666-114	17	22504 C	11	22810	45
28 C	31	666-118	17	22513	17	22823 A	15
40-181	21	666-149	19, 25, 29, 43	22516	9, 27, 43	22823 B	15
50-216 Blk	9	666-170	19	22519 C	25, 27	22829	23, 29
50-648 Blk	17	666-179	17	22519 H	23	22834	25
50-789 Blk	9	666-201	17	22519 J	27		
52 A	9	666-209	17	22524	13		
57 WD	33, 35, 39, 41	666-214	17	22528	9, 13, 25	22837	11
73	23	667 C	29	22537	31	22839	11, 13
73 A	9, 35, 39, 41	668-25	31	22539 H	17	22839 C	13
77	19, 25, 27, 29, 37, 43	668-28	31	22541 B	9	22840 A	33, 35, 39, 41
80	13	719	9, 27, 43	22542	9, 11, 37	22845 B	13
HA81	19	751	45	22548	13	22848	9, 11, 13, 37
82	25, 29	752	45	22557 B	31	22852	21
87	13	753	45	22559 A	19	22852 A	29
87 U	9, 21	907	27	22559 G	19	22863	25
88 B	31	1096	33	22560 A	21	22868 A	27
89	21, 31	1349 A	45	22560 B	15, 19, 25, 27, 29, 43	22874	43
90	9, 15, 27, 37	6042 A	21	22561	13	22882	21
91	33, 35, 39, 41	6905 H	33	22562	21, 37	22882 A	23
93	9, 37	6920 A	33	22562 A	19	22889 A	9
95	9, 17, 19, 31	6930 A	33	22563	23	22889 C	17
96	23	6941 A	33	22564	19	22889 D	17
97 A	23, 37	6942 A	33	22565 C	27, 37	22894 C	29
98	21, 23, 25, 27, 31, 43	7205 A	33	22568	11, 13	22894 D	25, 29
98A	9	7947	17	22569 B	9, 11, 15, 19	22894 F	19
109	31	9660 B	21	22570	13	22894 G	43
112 DW	33	9663	27	22571 A	17	22894 J	19
187 A	13	11940	33	22571 B	15	22894 P	27
188 D	45	12538	37	22571	15	22894 T	25, 29, 43
201 A	45	12934 A	27	22580 D	25, 29	22894 W	23
201 C	45	12957 E	11, 13	22581	9	22894 X	19
258	15, 27	12982	21	22585 A	13	22894 AA	43
258 A	15, 23, 25, 45	12987 A	29	22585 B	25	23254	13
269	23, 25, 29, 37	14077	27	22585 R	13	23254 C	13
303	27	15037 A	21	22586 R	19	23279 D	45
402	31	15465 F	23	22587	19	23306 A	11
421 D	45	15480 C	33	22588 A	13, 29	23306 T	11
434	37	21101 H	45	22589	37	23306 W	11
482	25, 27	21102 B	45	22591	19	23306 Z	11
531	15, 31, 37	21104 B	45	22593	27, 33	23306 AA	11
538	25	21104 H	45	22594	37	23306 AE	11
539	9	21104 V	45	22596	31	23306 AF	11
604	33	21114	45	22597	9	23307 J	11, 37
605	33, 35, 39, 41	21114 A	45	22597	9	23307 K	11, 37
605 A	35, 39, 41	21114 D	45	22647 K	45	23307 L	11, 37
627 A	37	21114 H	45	22650 CB	45	23307 M	11, 37
		21114 S	45	22651 CD	45	23307 N	11, 37
		21114 T	45	22703	11, 21	23405 M	11, 13
		21114 U	45	22711	9	23405 T	11, 13
		21114 W	45	22726	11, 13	23405 U	11
		21177 A	45	22729 A	17	23425 V	13
		21178 A	45	22729 B	17	23440 A	13
		21201	45	22729 C	21, 23	23440 B	13
				22729 D	19	23440 C	13
				22733	21		

NOTE: Only the basic part numbers are shown in the index. For various gauges, capacities, etc. available, refer to the listings on pages indicated.

NUMERICAL INDEX OF PARTS

<u>Part No.</u>	<u>Page No.</u>	<u>Part No.</u>	<u>Page No.</u>	<u>Part No.</u>	<u>Page No.</u>	<u>Part No.</u>	<u>Page No.</u>
23440 D.....	13	51236 E.....	25, 29	51493 BA.....	15	52730 T.....	35, 39, 41,
29066 R.....	19	51236 F.....	25, 29, 37	51493 BB.....	15	52730 U.....	33
29132 AC.....	29	51236 G.....	25, 29, 37	51493 BC.....	45	52730 V.....	33
29132 AH.....	43	51242 M.....	23	51493 BG.....	15	52730 W.....	33
29192.....	23	51243 C.....	19	51493 BH.....	15	52730 X.....	33
29192 T.....	23	51244 B.....	23	51493 BJ.....	15	52730 Y.....	35, 39, 41
		51244 L.....	23	51493 BK.....	15	52730 Z.....	35
29264 S.....	31			51493 BP.....	19	52730 AA.....	35
29348 P.....	19	51244 N.....	23	51493 BQ.....	15	52730 AB.....	35, 39, 41
29348 V.....	19	51246.....	23	51745.....	23	52730 AC.....	39, 41
29476 DV.....	25, 29	51247.....	19	51758.....	9	52730 AD.....	39, 41
29476 DX.....	25, 29	51250 A.....	19	51858.....	9	52730 AE.....	35, 39, 41
29476 JN.....	25, 29	51250 D.....	19	K51893.....	33	52730 AF.....	39, 41
29476 JP.....	19	51250 E.....	19			52736.....	37
29476 LE.....	19	51250 F.....	19	52350 A.....	13	52744.....	23
29476 NM.....	43	51254 C.....	17	52444 B.....	23	52749 A.....	13, 43
29486 F.....	37	51254 D.....	17	52480.....	13	52750.....	19, 21
33174 B.....	23	51254 J.....	19	52701 A.....	13	52750 C.....	13, 43
35178 D.....	17	51256 C.....	31	52701 B.....	13, 43	52770.....	43
35731 A.....	17			52702.....	13	52770 L.....	29
35761 D.....	17	51257 K.....	31	52703.....	13	52773.....	29
35766.....	13	51257 M.....	31	52704 A.....	13	52773 A.....	29
35772 H.....	13	51257 AA.....	17	52705 C.....	35	52773 B.....	29, 43
39141.....	23, 37	51280 A.....	13	52705 E.....	35	52773 C.....	29
		51280 E.....	15	52705 G.....	33	52773 D.....	29
		51280 J.....	13, 37	52705 J.....	35	52773 E.....	29
39237.....	27	51280 K.....	13	52705 M.....	39, 41	52773 P.....	43
39237 D.....	27	51281 P.....	13	52705 N.....	39, 41	52773 R.....	43
39237 G.....	27	51281 T.....	13	52708 B.....	23	52773 S.....	43
39258 C.....	37	51281 AC.....	13	52715.....	19	52773 T.....	43
39582 L.....	9	51282 Y.....	11			52774.....	29
39595.....	15	51282 Z.....	9, 11	52717 E.....	31	52774 A.....	43
41355 U.....	23	51282 AC.....	9, 11	52718.....	31	52775.....	29
41394 A.....	13	51282 AE.....	9	52720 B.....	33		
43242 N.....	21	51282 AH.....	11	52720 C.....	35	52776.....	37
43242 P.....	21	51282 AJ.....	11	52720 D.....	35	52776 A.....	37
43266.....	31	51282 AK.....	11	52720 G.....	33	52776 B.....	37
51054.....	19, 25, 29,	51283 H.....	31	52720 J.....	33	52776 C.....	37
	37	51285 B.....	9	52720 K.....	35	52776 E.....	37
51101 R.....	13	51290 T.....	15	52720 L.....	35	52776 F.....	37
51134.....	25	51291 A.....	9	52720 M.....	39, 41	51776 G.....	21
51134 C.....	25, 27	51292 A.....	31	52722.....	25, 29	52776 L.....	21
51134 J.....	25	51292 C.....	31	52722 B.....	25, 29	52776 P.....	21
51134 P.....	25	51292 D.....	31	52722 D.....	25, 29, 43	52776 R.....	21
51134 R.....	25	51292 F.....	31	52722 E.....	25, 29, 43	52776 T.....	21
51144.....	23	51292 G.....	31	52724 A.....	33	52776 V.....	21
51145 A.....	25, 29	51294 K.....	17	52724 B.....	33	52776 W.....	21
51147.....	19	51294 M.....	17	52724 C.....	35	52777.....	37
51150.....	19	51294 P.....	17	52724 D.....	35	52777 A.....	37
51193 S.....	17	51294 R.....	17	52724 G.....	33	52777 B.....	37
51213.....	23	51294 U.....	17	52724 H.....	33	52777 C.....	37
51215 J.....	19	51294 Z.....	17	52724 J.....	35	52777 D.....	37
51216 G.....	19	51295 A.....	15	52724 M.....	41	52777 E.....	37
51216 M.....	19	51295 B.....	15	52724 N.....	39, 41	52777 F.....	37
51216 N.....	19, 23	51301 D.....	13	52725.....	25	52777 G.....	37
51216 P.....	19	51306.....	25, 29	52725 A.....	23	52777 H.....	37
51221 C.....	19	51382 A.....	13	52726.....	35	52777 J.....	37
51225 W.....	25, 27	51406.....	25, 29	52726 C.....	39, 41	52777 K.....	37
51230 T.....	35, 41	51430 D.....	33	52728 C.....	35		
51235.....	25	51430 F.....	33, 35, 39,	52728 M.....	41	52777 M.....	21
51235 A.....	25, 37		41	52728 N.....	39, 41	52777 N.....	21
51235 G.....	25, 27	51435.....	27	52730.....	33	52777 P.....	21
51235 M.....	27	51435 B.....	27	52730 A.....	33	52777 R.....	21
51235 N.....	27	51480.....	13	52730 B.....	33	52777 S.....	21
51235 P.....	27	51491 C.....	31	52730 C.....	33	52777 T.....	21
51235 Q.....	27	51493 D.....	15	52730 D.....	35	52777 U.....	21
51235 R.....	27	51493 E.....	15	52730 E.....	35	52777 V.....	21
51235 S.....	27	51493 AG.....	15	52730 G.....	33	52777 W.....	21
51236 A.....	25, 29	51493 AH.....	15	52730 P.....	35	52777 X.....	21
51236 B.....	25, 29	51493 AY.....	15	52730 R.....	35	52777 Y.....	21
51236 D.....	25, 29					52777 Z.....	21

NOTE: Only the basic part numbers are shown in the index. For various gauges, capacities, etc. available, refer to the listings on pages indicated.

NUMERICAL INDEX OF PARTS

<u>Part No.</u>	<u>Page No.</u>	<u>Part No.</u>	<u>Page No.</u>	<u>Part No.</u>	<u>Page No.</u>	<u>Part No.</u>	<u>Page No.</u>
52777 AA.....	21	52818.....	31	52894 AB.....	15	52994 AC.....	15
52777 AC.....	21	52825 A.....	27	52894 AD.....	15	53678 N.....	21
52777 AE.....	21	52825 B.....	27	52894 AE.....	15	53701.....	13
52777 AF.....	21	52825 C.....	23	52894 AK.....	15	53782 B.....	13
52777 AG.....	21	52825 D.....	23	52904 B.....	9	53783 A.....	31
52778 B.....	37	52825 E.....	27	52904 E.....	9	53783 L.....	31
52778 D.....	21, 37	52834.....	27	52904 G.....	9	53783 M.....	31
52778 F.....	21, 37	52834 H.....	27	52921 B.....	43	53783 N.....	31
52778 G.....	37	52835 G.....	27	52922 C.....	25, 29	55235 D.....	21
52778 H.....	37	52835 K.....	27	52923 D.....	25, 29	55235 E.....	21
52778 J.....	37	52835 Q.....	27	52925 D.....	27	55244 G.....	23
52778 K.....	37	52835 S.....	27	52936.....	15	56334 E.....	25
52778 L.....	37	52835 U.....	27	52941 D.....	23	56343 D.....	19
52778 M.....	37	52835 V.....	27	52942 A.....	19	56344 B.....	43
52778 N.....	21	52836.....	27	52942 P.....	23	56354 A.....	19
52778 P.....	21	52836 C.....	27	52942 R.....	23	56356.....	31
52778 R.....	21	52836 H.....	27	52942 W.....	15	56382 X.....	31
52778 S.....	21	52841 A.....	23	52942 X.....	15	56390 E.....	17
52778 T.....	21	52842 G.....	31	52942 Y.....	9	56458.....	19
52778 U.....	21	52882 P.....	9	52943 L.....	19	56458 A.....	19
52778 V.....	21	52882 U.....	13	52944 T.....	15	56958.....	19
52778 W.....	21	52882 W.....	9, 11	52944 U.....	15	56958 A.....	19
52778 X.....	9	52882 Y.....	9	52949.....	13	57744 A.....	43
52779.....	29	52882 AA.....	9	52951 C.....	19	57770.....	9
52779 A.....	29	52882 AC.....	9	52953.....	27	57836 F-40.....	27
52779 B.....	43	52882 AD.....	9	52957 C.....	9	57836 F-45.....	27
52779 C.....	43	52882 AE.....	13	52958 B.....	9	57836 F-50.....	27
52782 C.....	9, 11	52883 R.....	17	52958 D.....	9	57885.....	9
52782 D.....	9	52883 S.....	31	52970 T.....	9	57885 B.....	9
52794 G.....	17			52978 G.....	11	61267 G.....	27
52794 H.....	15			52980 A.....	13	79048.....	21
52804 E.....	9	52885 L.....	9	52982 D.....	13	80265.....	29, 43
52813.....	23	52890 C.....	15, 17	52982 E.....	13	80662.....	37
52817.....	31	52891 B.....	17, 19	52985.....	9	80692.....	37
52817 E.....	31	52892.....	31	52994 B.....	9		

NOTE: Only the basic part numbers are shown in the index. For various gauges, capacities, etc. available, refer to the listings on pages indicated.

Here are Oil Specifications for Union Special Sewing Machines



Specification 174 specifies a high quality petroleum oil, viscosity 100 seconds at 100°F. Recommended for all oiling applications on high speed machines.

Specification 175 specifies a high quality petroleum oil, viscosity 100 seconds at 100°F., water white or with a maximum A.S.T.M. color number of 1. For use where freedom from oil staining is paramount.

Specification 87 specifies a high quality petroleum oil, viscosity 300 seconds at 100°F.

Specification 100 specifies a general purpose high quality grease for use in ball bearings and transmitters. It is similar to commercial N.L.G.I., grease No. 3. Where No. 3 grease is not obtainable, No. 2 may be used.

UNION SPECIAL

SPECIFICATION NO.	174	175	87
Viscosity S.S.U. at 100°F	90-125	90-125	300-350
Flash (Min.)	350	350	350
Pour (Max.)	20	20	20
Color A.S.T.M. (Max.)	3	1	3
Neutralization No. (Max.)	0.10	0.10	0.10
Viscosity Index			
(D & D Min.)	85	85	85
Compounding	None	None	None
Copper Corrosion (Max.)	1A	1A	1A

*Anline No.

175-225 175-225 175-225

*Used with Buna N Rubber "O" Retainers

NOTE 1: The use of non-corrosive additives in oils meeting above classification is desirable but not essential. These may include:

1. Oxidation inhibitors
2. Rust inhibitors
3. Lubricity additives
4. Anti-oxidants
5. Film strength additives

These additives must be completely soluble in the oil and not removable by wick feeding nor shall they separate.

NOTE 2: Oils containing the following type additives shall not be used at any time:

1. Extreme pressure additives—corrosive
2. Tackiness or adhesive additives
3. Lead soap additives
4. Detergents



**UNION SPECIAL
CORPORATION**

Helpful, authoritative information on the most efficient types of equipment for making virtually any machine sewed article is available from Union Special's Sales Promotion Department. Among the many interesting, illustrated bulletins that are available without obligation are the following:

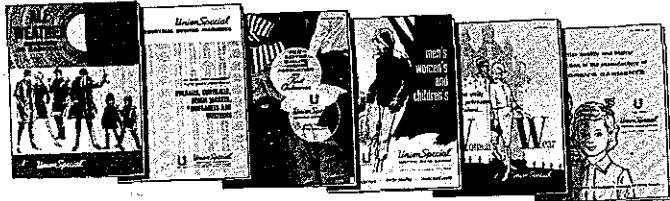

- No. 240, "Men's, Women's, Children's Footwear"
- No. 249, "Rainwear"
- No. 250, "Men's Dress Shirts"
- No. 251, "Service Shirts and Pants"
- No. 252, "Men's Shorts and Pajamas"
- No. 253, "Overalls, Coveralls, and Dungarees"
- No. 254, "Men's Knit Underwear"
- No. 256, "Knit Outerwear"
- No. 259, "Men's Sports Shirts"
- No. 260, "Work Gloves"
- No. 262, "Cotton, Burlap, Jute, and Multiwall Paper Bags"
- No. 263, "Men's Clothing"
- No. 264, "Men's Women's, Children's Jackets"
- No. 265, "Women's Wear"
- No. 266, "Women's Wear And High Fashion"
- No. 267, "Corsets, Girdles, Brassieres"
- No. 268, "Children's Wear"
- No. 269, "Mattresses, Slip Covers, Furniture Upholstery"
- No. 271, "Awnings, Canopies, Tents, Tarps"
- No. 273, "Curtains & Drapes"
- No. 610, "Klipp-it"
- No. 710, "MCS ForMation Unit"
- No. 730, "MCS Automatic Dual Underfront Shirt Hemmer"
- No. 740, "MCS Automatic Rib-Knit Cuff Machine"
- No. 750, "Fusing Presses"
- No. 1100, "Lewis Blindstitch, Chainstitch, Lockstitch, Machines"
- No. 1105, "Button Sewers—Ticket Tackers"
- "Columbia Blindstitch, Saddle Stitch, and Tie Closing Machines"
- No. 1500, "Alteration Department Machines"



**UNION SPECIAL
CORPORATION**

**HERE ARE HELPFUL
BULLETINS and CATALOGS
TO HELP YOU SOLVE
SEWING PROBLEMS**



Union Special Wants to Help You Cut Sewing Machine Maintenance Costs

Union Special is offering two practical systems to help pinpoint and reduce your sewing machine maintenance costs: a record keeping system to help spot machines requiring abnormally high maintenance, and a parts inventory system to speed routine repairs.

Machine Maintenance Records

Repair-prone machines or inexperienced competent operators can eat up your maintenance dollars in short order. To help spot these problems, Union Special suggests two variations of a simple maintenance record keeping system using cards provided by Union Special.

The first system utilizes a "Machine Maintenance Record" card (Form 237) for each sewing machine in a plant. When a repair is required, the card is pulled from the file and the repair date, parts used, and their cost are entered in the spaces provided and the card is refiled,

The second system is normally used when more detailed information on repair costs is desired. Two record cards are used: a "Repair Request Card" (Form 234), and a "Machine Repair Record" (Form 233). When a machine requires service, the forelady or foreman fills out the top of a "Repair Request Card" and gives it to a mechanic. He fills in the time the repair work is started, the parts used and their cost,

and the completion time. This data is then transferred to the permanent "Machine Repair Record" kept in the office.

Whichever system is used, management now has an invaluable tool to reduce needless maintenance costs.

Repair Part Inventories

While record keeping tells management which machines require abnormally high maintenance, it does little to help reduce the downtime caused by routine repairs. To alleviate this situation, Union Special recommends that manufacturers establish a formal parts inventory system for each type of sewing machine they operate.

Excessive machine downtime and wasted hours by mechanics can be eliminated with an orderly in-plant inventory of the most commonly needed parts. There is no longer a need to cannibalize other machines for spare parts. Long waits for deliveries are avoided and machine downtime is kept to a minimum. The cost of a parts inventory is small when the overall savings are considered.

For free sample copies of the machine record cards and spare part inventory lists for a variety of the most popular machines, contact your local Union Special Representative or write direct to Union Special.

Union Special
FINEST QUALITY

Style 52700 BV-8

Suggested Minimum Spare Parts List*

Part Number	Description	Minimum Quantity Per 5 Machines	Part Number	Description	Minimum Quantity Per 5 Machines
52720-J-8	Presser foot	1	52904 G	Cast off wire	1
91	Screw for presser foot	2	52708 B	Looper	1
7205 A	Feed dog	1	73	Looper screw	2
22528	Screw for feed dog	2	21225 7/32	Looper gauge	1
52724 H-8	Throat plate	1	73 A	Screw for cast off wire	2
87	Screw for throat plate	4	29484	Screw assortment	1
121 GBS	Needles (specify size)	200			
88 B	Needle set screws	4			

*The parts and quantities listed above are intended to assist you in setting up the initial inventory of spare parts. An efficient inventory can only be established according to actual usage. The nature of the sewing operation will determine actual usage.

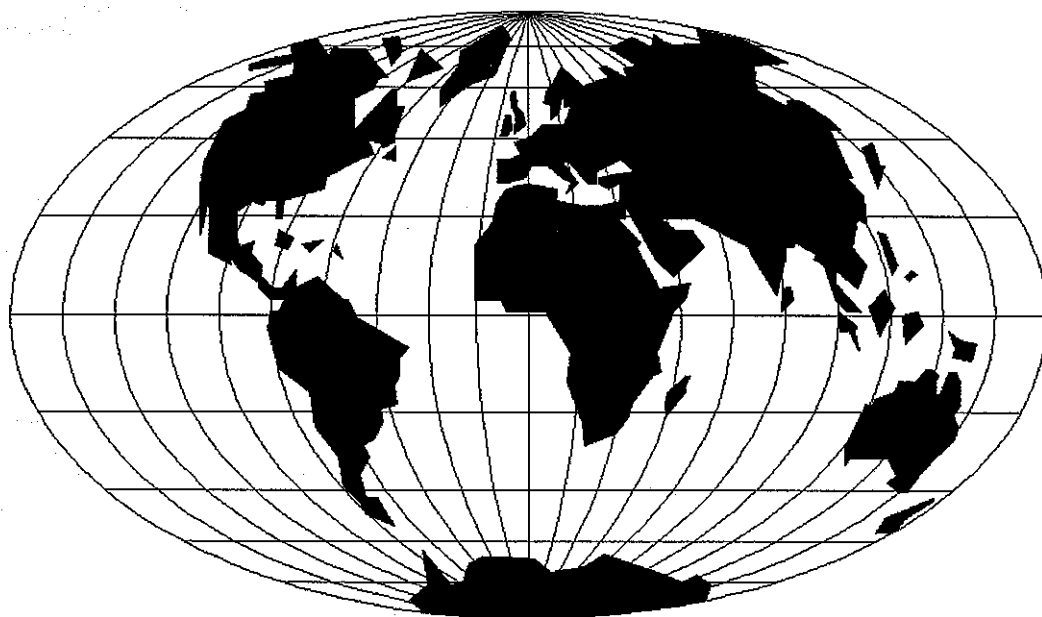

WORLDWIDE SALES AND SERVICE

Union Special Corporation maintains sales and service facilities throughout the world. These offices will aid you in the selection of the right sewing equipment for your particular operation. Union Special Corporation representatives and service technicians are factory trained and are able to serve your needs promptly and efficiently. Whatever your location, there is a qualified representative to serve you.

Corporate Office: One Union Special Plaza
Huntley, IL 60142
Phone: 847•669•5101
Fax: 847•669•4454

European Distribution Center: Union Special GmbH
Raiffelsenstrasse 3
D-71696 Möglingen, Germany
Tel: 49•07141•247•0
Fax: 49•07141•247•100

Brussels, Belgium
Charlotte, N.C.
Hong Kong, China
Huntley, IL
Leicester, England
Lille, France
Miami, FL
Milan, Italy
Möglingen, Germany
Montreal, Quebec
Osaka, Japan
Santa Fe Springs, CA
Suwanee, GA
Wayne, NJ

Other Representatives throughout
all parts of the world.



Union Special
INDUSTRIAL SEWING EQUIPMENT